

CATALOG

SEASON 2023

BOVINE | HORSE | HOG | GOAT | OVINE | DEER



HANDLING



HOOF TRIMMING



IDENTIFICATION



WEIGHING



MARÉCHALLE

CONTENTION ■ PESAGE ■ IDENTIFICATION

French company specialized in the manufacturing
of weighing and handling
equipment for livestock for over 50 years.

www.marechalle-pesage.com

EDITO

THIS YEAR, WE ARE PLEASED TO INVITE YOU ON A JOURNEY THROUGH TIME. LET US TELL YOU THE STORY OF MARECHALLE PESAGE FROM ITS CREATION TO THE PRESENT DAY.



1947

PIERRE JOSEPH MARECHALLE, BALANCE TECHNICIAN.



1952

PIERRE JEAN, SON OF PIERRE JOSEPH, IS VENTURING INTO THE MANUFACTURING OF WEIGHING AND BAGGING SCALES FOR COAL.



1963

PIERRE JEAN MARECHALLE ACQUIRES A PATENT, MARKING THE BEGINNING OF LIVESTOCK WEIGHING SCALES REDUCTION.



LIVESTOCK WEIGHING SCALES ARE A HIT AT AGRICULTURAL SHOWS, WITH PEOPLE LINING UP TO PLACE THEIR ORDERS, PIERRE MARECHALLE STARTS TO BECOME KNOWN AND THE MARECHALLE BRAND BECOMES A REFERENCE IN THE INDUSTRY!



PM 2400 HANDLING AND WEIGHING CRUSH: OUR CRUSHES ARE DESIGNED FOR ANIMAL WELFARE AND THE FARMER CAN WORK ALONE SAFELY!



1993

PIERRE CLAUDE, SON OF PIERRE JEAN, CREATES WITH HIS WIFE LYDIE, MARECHALLE PESAGE METROLOGIE, AN INDUSTRIAL WEIGHING INSTRUMENTS COMPANY, WEIGHBRIDGES, AND REPAIR SERVICES.



2008

NEW HANDLING CRUSH ADJUSTABLE IN WIDTH PM 2800



2013

INNOVATION OF A STANDALONE WEIGHING CAGE: THE PM6000 LIBERTY. INNOV' SPACE 3-STAR AWARD-WINNING PRODUCT.



2014

LAUNCH OF A NEW ELECTRIC HOOF TRIMMING CHUTE FOR DAIRY COWS, THE PM 4500.



2015

RELOCATION TO A NEW FACTORY IN CHAUNY, IN NORTHERN FRANCE! WITH A LARGER FACTORY AND MORE FUNCTIONAL OFFICES, OUR PRODUCTS WILL CONTINUE TO EVOLVE.



3016

ON THE WAY TO NEW ADVENTURES!



TABLE OF CONTENTS

HANDLING

Handling	2
Headgates	3 to 4
Ovine handling alley	5
Handling headgates	6 to 11
Handling crushes	12 to 19
Pneumatic and hydraulic automation	20
Mobile handling equipment	21 ot 23

HOOF TRIMMING

Hoof trimming	24
For bovine	25 to 30
For Horses	31

IDENTIFICATION

Identification	32
EID tags	33
EID Panel readers	34 to 37

WEIGHING

Weighing	38
Weighing system adaptable for crushes	39 to 41
Weighing indicators	42 to 45
Weighing platforms	46 to 48
Small livestock weighing crates	49 to 52
Livestock weighing crushes	53 to 57

FACTORY	58 to 59
INFORMATIONS	60
INDEX	61
NOTES	62



BOVINE



MEAT BOVINE



CALF



HORSES



PORCINE



GOAT



OVINE



DEER



RS232 interface



USB interface



Internal rechargeable battery



Backlit display



Totalisation



Protection factor



Off Legal Metrology



Wifi



Bluetooth



Daily Live weight Gain

All our products are on our website:
www.marechalle-pesage.com

Non binding document.
In a sense of continuously improving our products, we may change, modify, add or remove technical features without notice.

HANDLING

WORK SAFELY WITH THE SUITABLE SOLUTION



- Working with the suitable solution, it's providing a safe work environment for you and your employees.
- You win a precious time !
- The animal, once strongly restrained, will become calmer and more peaceful, allowing you to treat and handle it more easily.
- A peaceful and well treated animal will give a tender meat and produce more milk.

You win in productivity !



SORTING GATE PM 90 FOR BOVINE

>>> 3 versions: manual, pneumatic and électro-pneumatic



Internal dimensions

length 155 cm
width 116,2 cm
height 220 cm

Weight: 316 kg

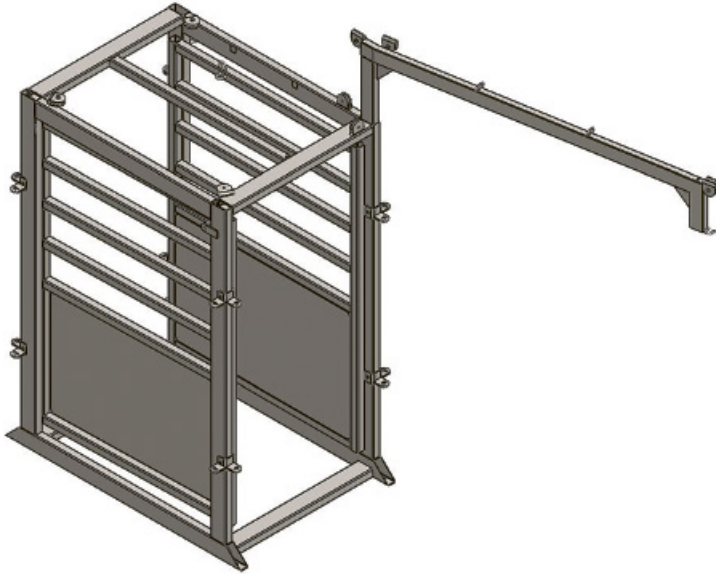

MANUAL TECHNICAL FEATURES

- 3 possible ways.
- 2 cords for the doors to go in one direction or another by pulling.
- Long control arm to be able to maneuver from a distance.

PNEUMATIC FEATURES

- 3 possible ways.
- Require connection to air compressor.
- Pneumatic cylinders controlled by distributors on a fixed support.
- Silent door with pneumatic cylinders.
- Brackets for posts.

ÉLECTRO-PNEUMATIC TECHNICAL FEATURES

- 3 possible ways.
- Requires connection to air compressor.
- Requires 220V connection.
- Electro-pneumatic cylinders with control box and remote control to operate the doors from a distance.
- Silent door with pneumatic cylinders.
- Brackets for posts.

OPTIONS

MP Box (interoperability)

Programming for management software (BAOBA, BOVICLIC, ISAGRI)

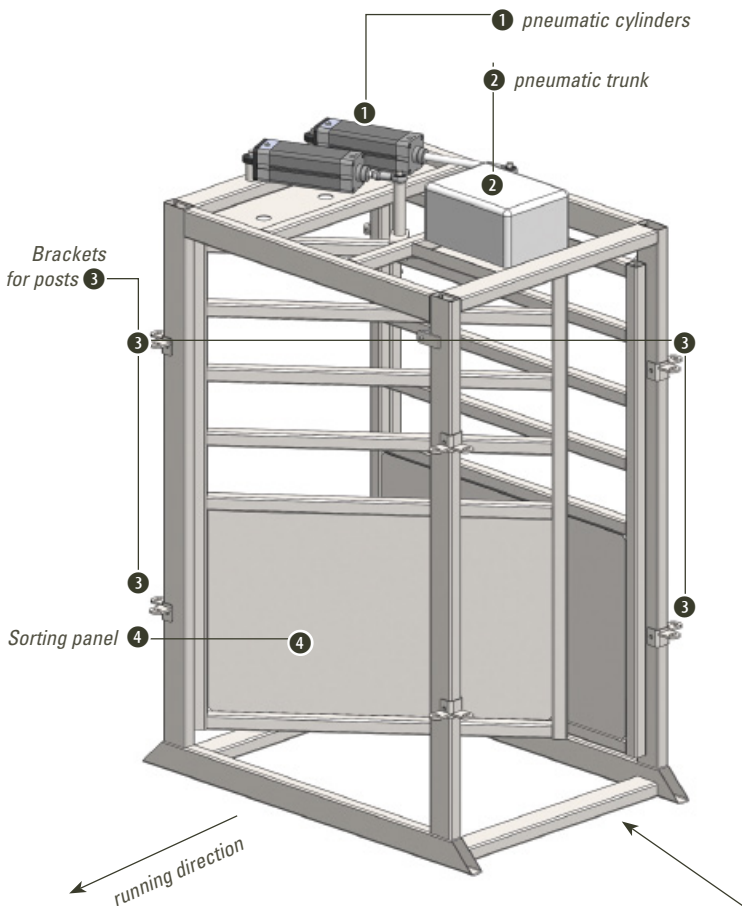

SHEEP SORTING GATE PM 91

>>> 3 way electro-pneumatic

Internal dimensions

length 101 cm
width 100 cm
height 141cm

Weight: 85 kg

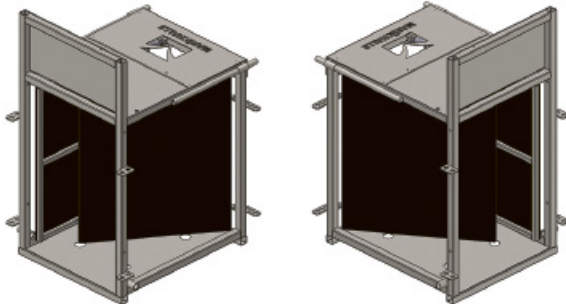
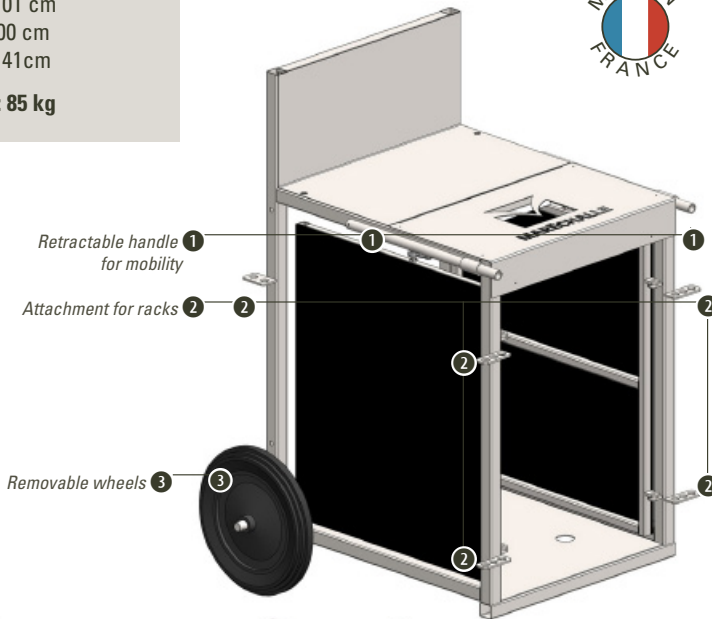

OPERATIONAL FUNCTIONING

- Requires an identification system with Bluetooth connection.
- Requires a weighing system with Bluetooth connection.
- Compatible with android smartphone only.
- Required compressed air connection.
- Requires 220V connection.

TECHNICAL FEATURES

- 3 possible directions.
- Equipped with MP Box (interoperability).
- Silent doors with pneumatic cylinders.
- Movable on wheels.
- Attachment for racks.
- Non-slip rubber mat.
- Painted product only

OPTION

Programming for management software (BAOBA, BOVICLIC, ISAGRI)

SHEEP SORTING GATE PM 92

>>> manual 2-way stop

Internal dimensions

length 56 cm
width 47,8 cm
height 90 cm

Weight: 70 kg

External dimensions

length 68 cm
width 68,7 cm
height 111,2 cm

Weight: 70 kg

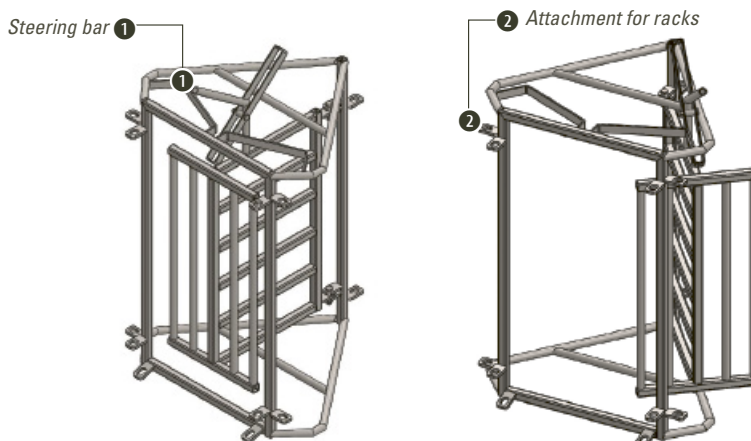

FEATURES

- 2 possible directions, right or left.
- Light and silent door.
- Attachment for racks.
- Stop and sort, the door allows to stop the animals before sending them to the left or right.
- Openwork door to make the animals move forward.
- Galvanized product only.

WATCH
OUR VIDEOS ON



www.marechalle-pesage.com

HANDLING ALLEY

>>> for sheep

Dimensions quarter circle

radius 1215 mm
internal width 500 mm
height 900 mm

Dimensions hurdle

length 2400 mm
height 900 mm



NEW



FEATURES

- Handling alley to compose according to your needs.
- Structure in painted steel and plastic panel.
- Straight 2400 mm plastic sheeted hurdles.
- Plastic panel quarter circle.
- The opaque plastic panel allows the animal to be guided quickly.
- The plastic greatly reduces the noise of knocks and vibrations.
- Very light product to handle.

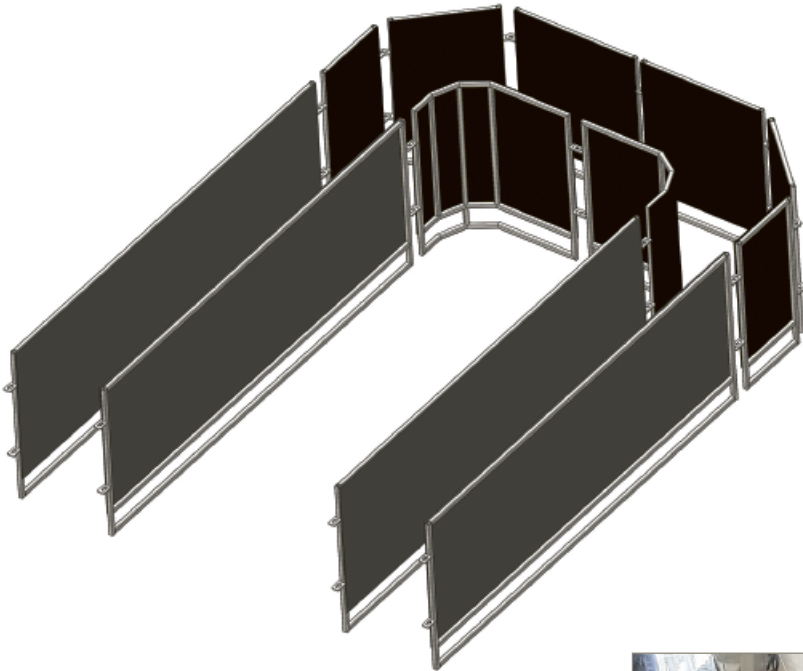

USER BENEFITS

- The opaque plastic panel allows the animal to be guided quickly.
- The plastic greatly reduces the noise of knocks and vibrations.
- Very light product to handle.

AUTOMATIC HEADGATE PM 97

>>> progressive tightening



Internal dimensions
width 82 cm
height 171 cm

External dimensions
width 178 cm
height 203 cm
depth 121 cm

Weight
290 kg

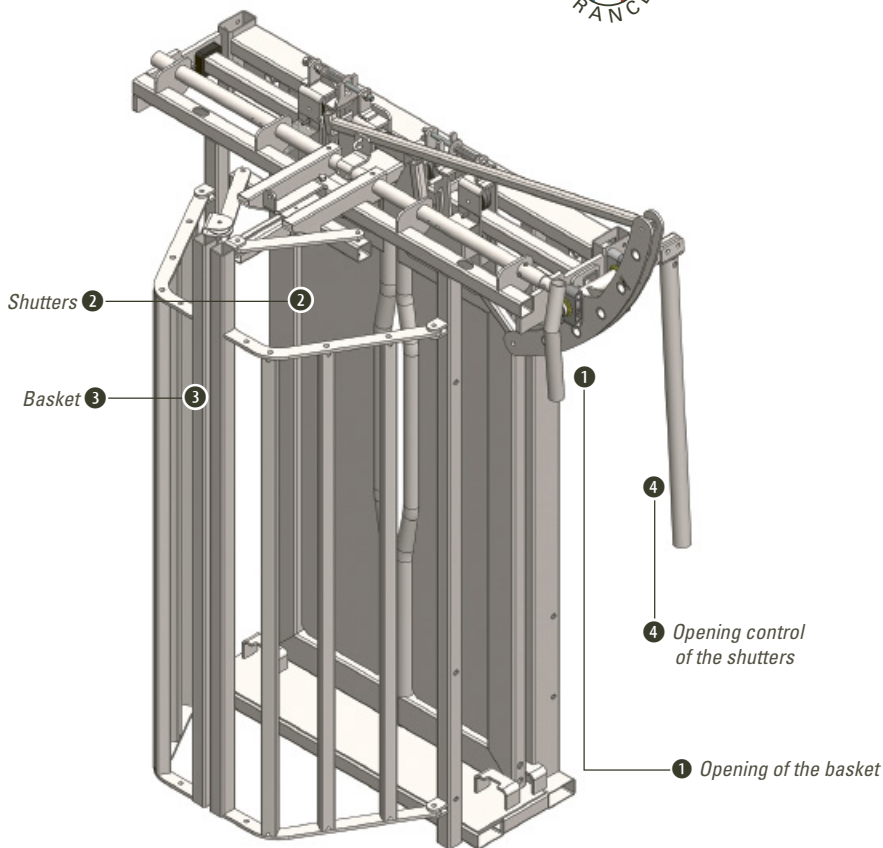

TECHNICAL FEATURES

- Good access for all care on the front of the animal.
- Quick and silent opening and closing of shutters.
- Automatically adapts to the neck of the animal.
- Secure retaining gate.
- Opening of the safety basket propelled by a cylinder.
- Solid shutters from top to bottom.
- Product available paint or galvanised.

OPTIONS

Removal of the basket

Head lift

Set of 4 brackets for fixing fences

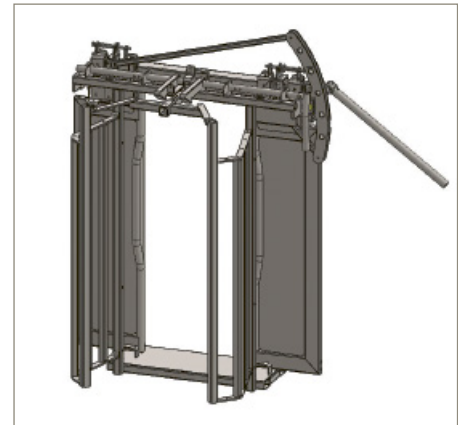

ANIMAL COMFORT

- Silent door.
- Permit to release easily the animal if necessary.
- No risk of injury.

USER BENEFITS

- Ergonomic.
- Safe work for one person.
- Very light and flexible controls.
- New continuous blocking system for more security.

WATCH
OUR VIDEOS ON



www.marechalle-pesage.com

REINFORCED HEADGATE PM 94

>>> hydraulic or pneumatic

Internal dimensions
width 82 cm
height 171 cm

External dimensions
length 178 cm
width 203 cm
height 90 cm

Weight
380 kg

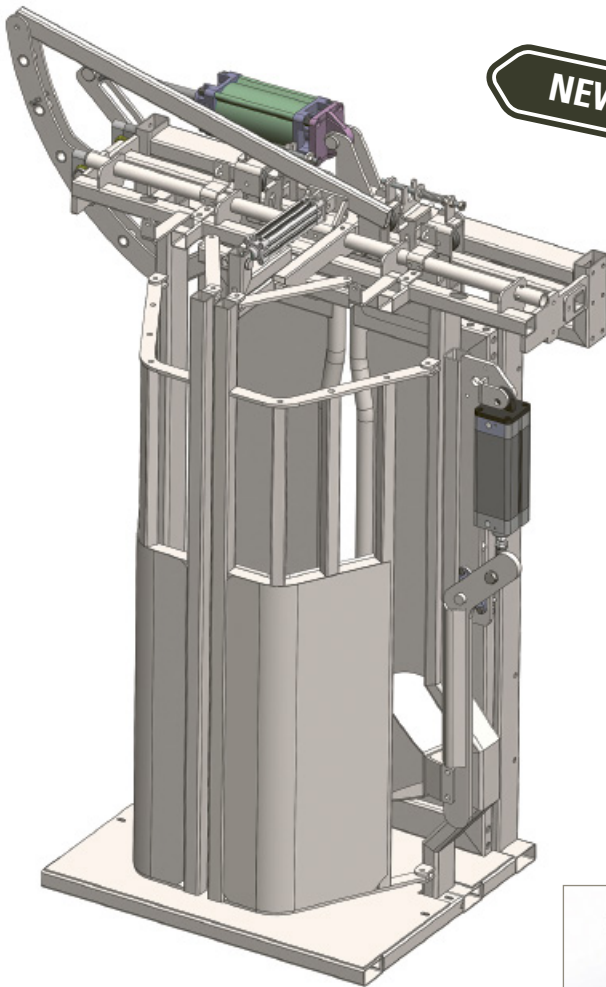

NEW

TECHNICAL FEATURES

- Hydraulic or pneumatic automation, as required.
- Reinforced gate engineered for a significant passage of animals.
- 5mm steel tube frame.
- Reinforced head lift included, hydraulic or pneumatic (with door safety lock on hydraulic system).
- Half-full safety-basket.
- Solid shutters from top to bottom.
- Elastomeric buffers and bearings to absorb noises.
- Angles between tubes and silicone sheets to reduce noises.
- Floor under the basket to make the exit fluid.
- Galvanised product only.

USER BENEFITS

- Speed and comfort of work, avoids repetitive movements and musculoskeletal disorder.
- Silent system, the animal remain calm and not frightened.
- Save time and gain productivity for the breeder and less fatigue for the user.

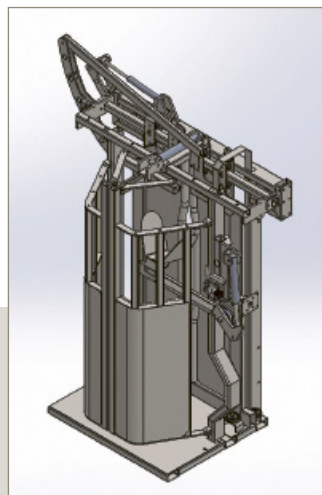

PM 94 hydraulic

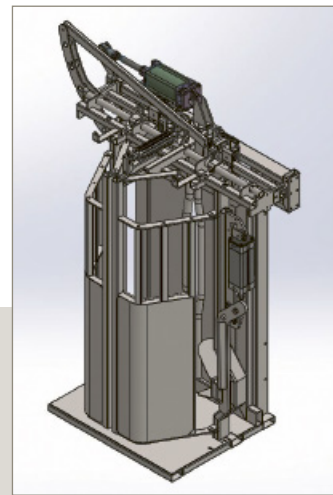

PM 94 pneumatic

UNIVERSAL HEADGATE PM 93



Internal dimensions
width 82 cm
height 180 cm
depth 50 cm

Gross weight: 268 kg



TECHNICAL FEATURES

- Reversible headgate, handles of safety basket and shutters can be fixed on right or left side.
- Good access to the animal for all treatments on the head.
- Fast and silent opening and closing of the safety basket with rotating handle.
- Shutters are closer to the structure, which avoids trapping of legs or head between the shutters and the frame.
- Quick catch of the animal with safety basket.
- Fast and silent opening and closing of shutters.
- Securing front basket.
- Crank adjustment for neck aperture.
- Unlocking of the basket possible to have a larger access to the animal's head.
- Product available in paint or galvanized (shutters always galvanized).

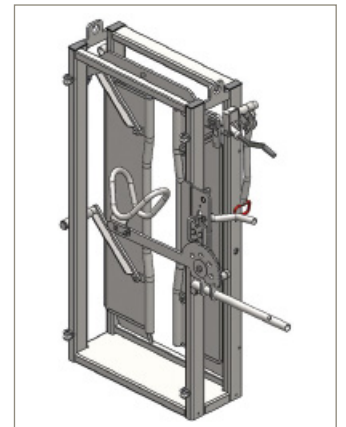
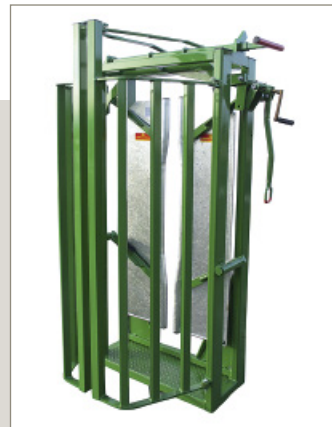
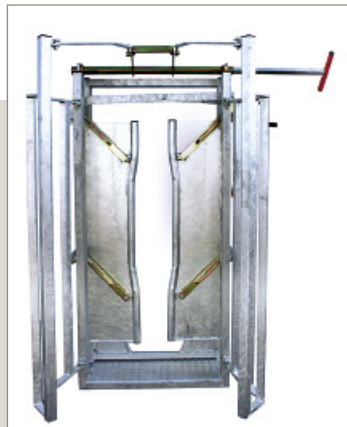
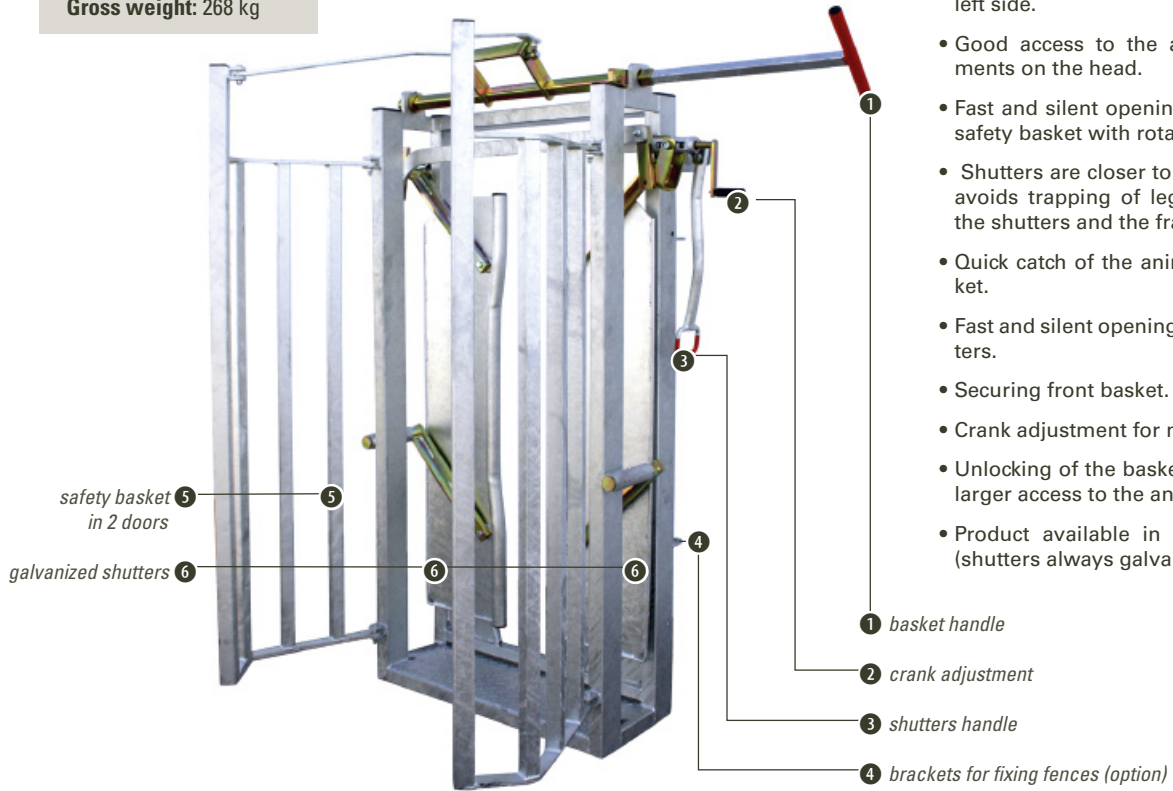

ANIMAL COMFORT

- Silent headgate.
- Fast release of the animal if necessary.
- Less risk of injury.

USER BENEFITS

- Time saving on treatments.
- Work in total safety by a single person.
- Handles can be installed on the right of left side, without return to factory.
- Easier to handle.

OPTIONS

- Muzzle boom lift
- Manual or Pneumatic scoop head up
- Pneumatic automation (see p.12)
- Brackets for fixing fences

AUTO-LOCKING HEADGATE PM 85



Internal dimensions

width 82 cm
height 170 cm
depth 60 cm

Gross weight: 195 kg



neck aperture adjustment 4

autolocking shutters 5



TECHNICAL FEATURES

- For dehorned animals only.
- The animal blocks itself by pushing on the shutters with its shoulders.
- Quick work automatism.
- Good access to the front for all treatments.
- Easy adjustable neck aperture.
- Opening lever can be mounted on right or left side.
- Possibility to unlock the system if we don't want to block the animals.
- Possibility to lift the opening lever from a distance using a rope.
- Product available in paint or galvanized.

1 opening handle for rearward exit

2 opening handle for forward exit

3 opening help handle

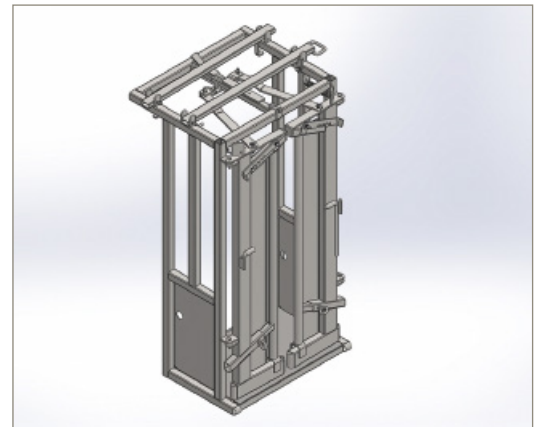

USER BENEFITS

- Work from a distance: limited movements.
- Work comfort: less handling.
- Fast use: time saving.
- Use by a single person.

OPTIONS

- Muzzle boom lift
- Manual or Pneumatic scoop head up
- Brackets for fixing fences



www.marechalle-pesage.com

CORNADIS HEADGATE PM 80



Internal dimensions
width 82 cm
height 170 cm
depth 30 cm

Gross weight: 100 kg



rack of shutter adjustment ①

shutter ②

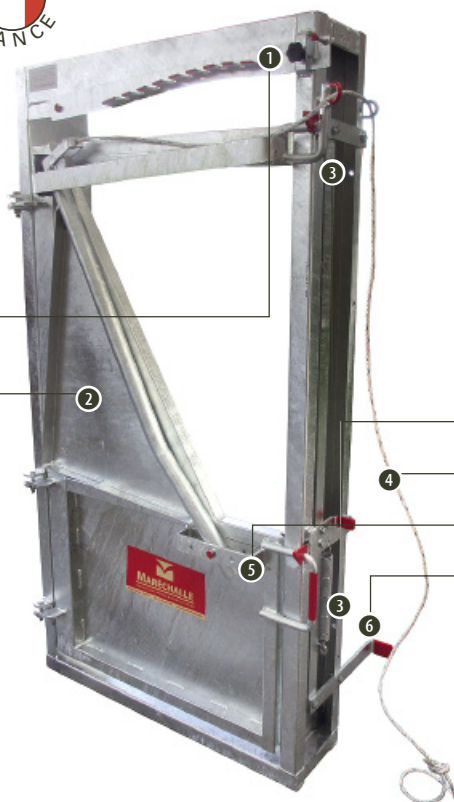
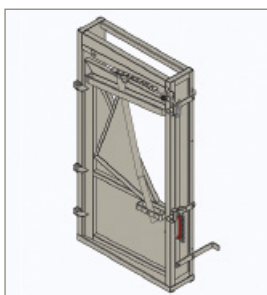

③ drilling for fastening

④ nylon cable for shutter closing

⑤ 3 positions shutter adjustment

⑥ pedal to open the gate

TECHNICAL FEATURES

- Headgate to be installed at the end of a corridor.
- Simple closing of the neck aperture with the rope.
- Possibility of blocking various sizes of animals.
- Opening with maneuverable pedal by foot or hand.
- Product available in paint or galvanized.

OPTION

Reverse model for the door: handle on the left side from a front view

PORTE PM 87



Internal dimensions
width 82 cm
height 170 cm

Gross weight: 130 kg



crank adjustment for neck aperture ①

shutters handle ②

shutters with central closing ③

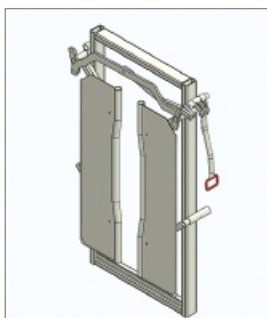

TECHNICAL FEATURES

- Can be used as a front door, intermediate or back door in a crush or alley.
- This door is mandatory as back door on order of a pneumatic crush, because it avoids pinching animals' legs at the entrance to the crush.
- It is also mandatory as back door on order of crush with suspended weighing system PM45, because the opening handle of door PM 88 becomes inaccessible with the structure of the suspended weighing.
- Symmetrical central closure.
- Fast and silent opening and closing of shutters.
- Crank adjustment for neck aperture.
- Product galvanized only.
- Reversible gate, the handle can be fixed on right or left side.

OPTIONS

Back door PM 87 in replacement of the door PM 88 (mandatory for an order of a pneumatic crush or crush with suspended weighing)

Brackets for fixing fences

SLIDING DOOR PM 81



Internal dimensions
width 82 cm
height 170 cm



TECHNICAL FEATURES

- Lateral sliding on the side of your choice.
- Door on bearings.
- Light and silent.
- To be installed on a crush or a mobile corridor, or as an intermediate door inside a fixed alley.
- Product available in paint or galvanized.

OPTION

Sliding door PM 81 in replacement of the back door PM 88

BACKSTOP DOOR PM 89



Internal dimensions
width 82 cm
height 170 cm

Gross weight: 60 kg

clappers with springs ①

mechanical backstop ②

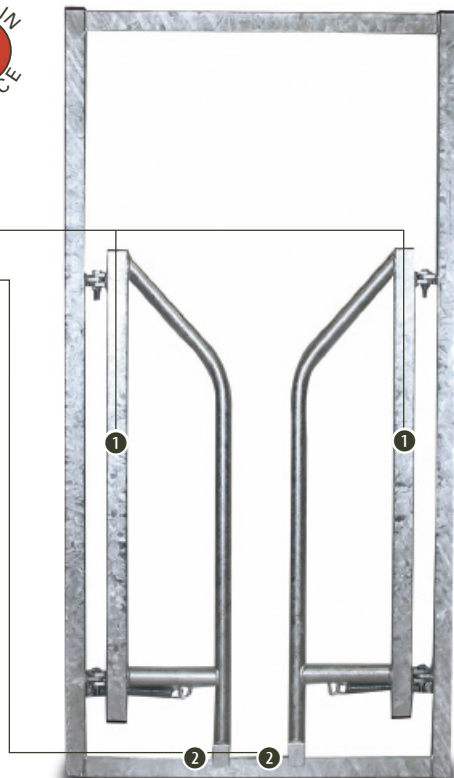

TECHNICAL FEATURES

- To be installed as an intermediate door inside a fixed corridor.
- Can also be installed as a back door in a cattle crush.
- The animal pushes on the flaps to go through, but it cannot move back because the flaps go back to a stop toe.
- Product galvanized only.

OPTIONS

Backstop door PM 89 in replacement of the back door PM 88

Brackets for fixing fences

MULTIFUNCTION CRUSH ALL IN ONE PM 2400

>>> handling - hoof trimming - weighing



Internal dimensions

length 240 cm
width 82 cm
height 170 cm

Gross weight: 550 kg

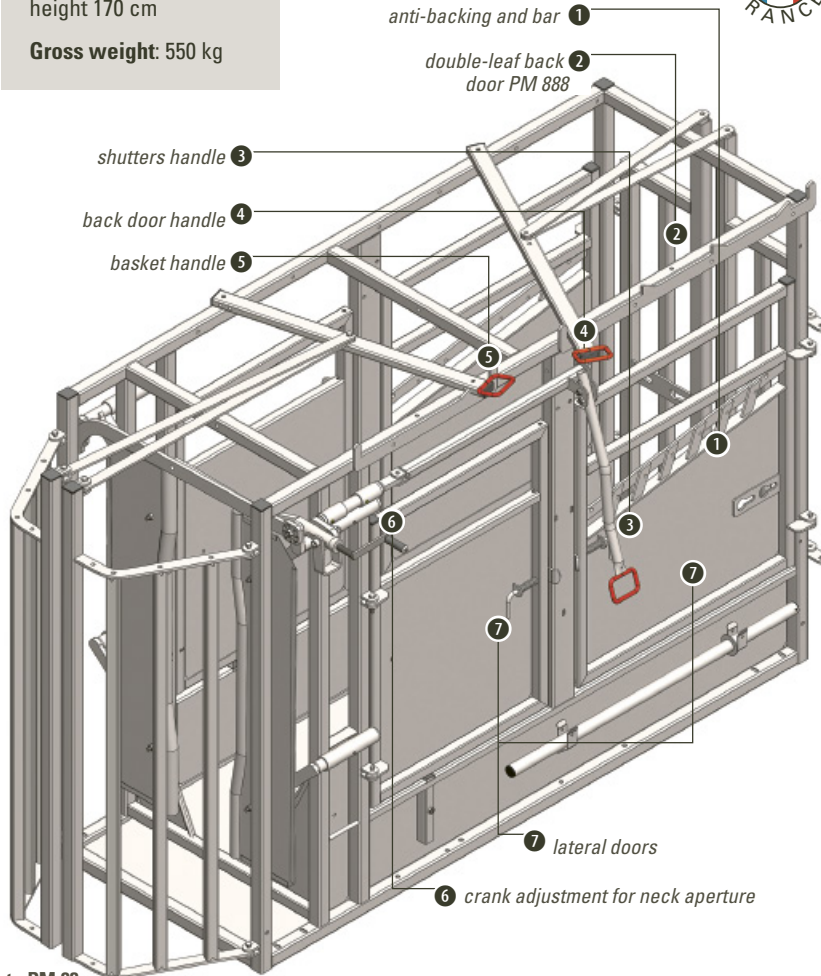

universal headgate PM 83

TECHNICAL FEATURES

- Front gate to choose from: PM 83, PM 85 or PM 80.
- 4 lateral doors for a total access to the animal.
- Three-point linkage to be hooked by tractor.
- Adaptable to all cattle breeds.
- Good stability of the animal.
- Product available in paint or galvanized.

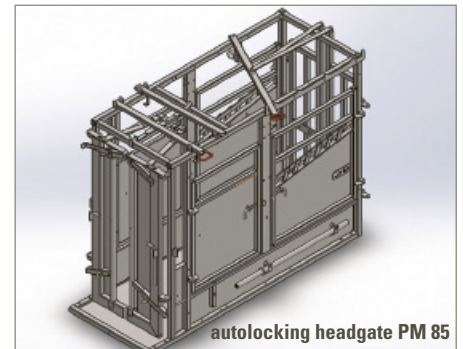
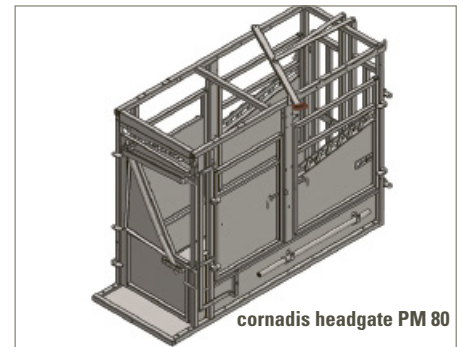

ANIMAL COMFORT

- Good hold of the cow.
- Safety and welfare of the animal.

USER BENEFITS

- Protection against bumps legs.
- Handling and cares in total safety.
- Fast operation.

OPTIONS

- > Reverse model for crushes: handles on the left side from a front view
- > SUPER Model (hoof trimming equipment)
- > Electric SUPER Model (lifting legs with one motor)
- > Medicine box
- > Rubber mat
- > Muzzle boom lift
- > Manual or pneumatic scoop head up
- > Lift ring for transport
- > Removable galva width reducer in 2 parts
- > Removable central pole
- > Galva lateral caesarean door
- > Insemination back door PM 82
- > Pneumatic pendulum backstop

SQUEEZE CATTLE CHUTE PM 2805

>>> with reinforced width reducer



Internal dimensions

length 270 cm
width 40 à 82 cm
height 170 cm

Gross weight: 750 kg

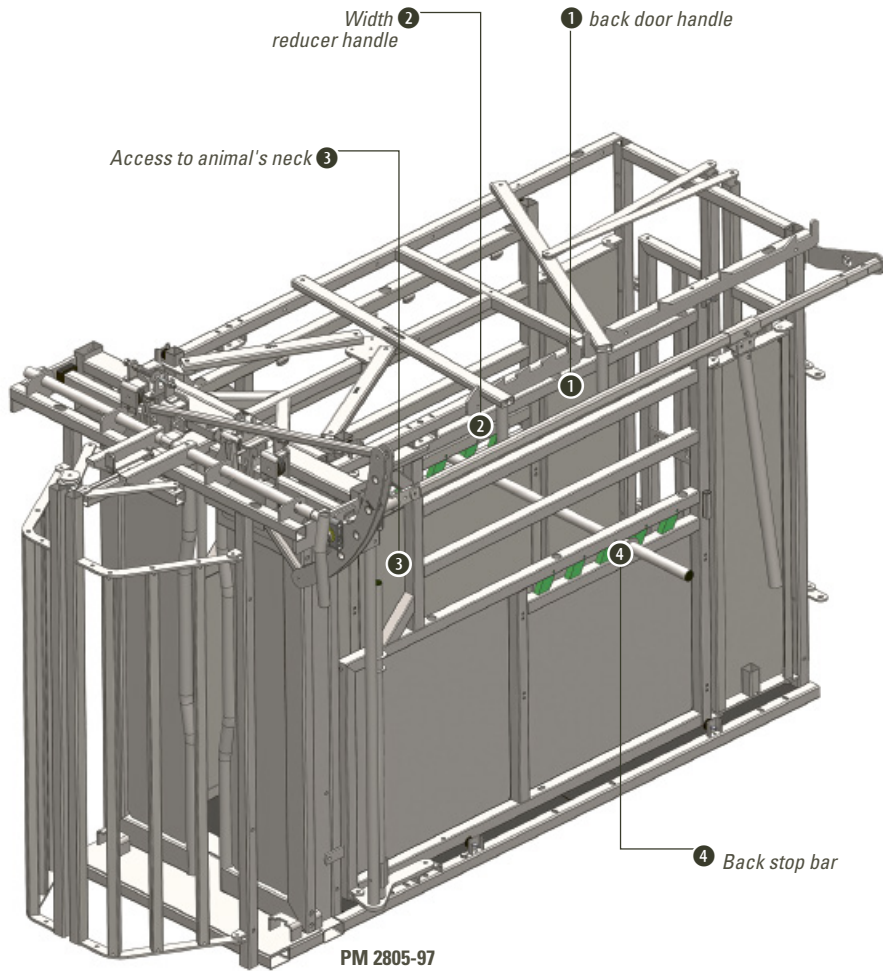

TECHNICAL FEATURES

- Headgate to choose from PM97, PM93 or PM85.
- Adjustable sides on width for all sizes of animals (4 positions from 40 cm to 82 inside).
- Reinforced width reducer.
- Standard rubber mat, silent chute.
- Access to the animal's neck at the front of the chute for vaccination.
- High fixed tubes.
- Back stop bar.
- Total immobilization of the animal.
- Save time, the animal cannot turn around in the chute.
- Work in total safety, a well-maintained animal is a calmer animal.
- Product available in paint or galvanised.

OPTIONS

- Reverse model for crushes: handles on the left side from a front view.
- Medicine box.
- Muzzle boom lift.
- Manual, pneumatic or hydraulic head lift
- Lift ring for transport
- Forks passage
- PM82, PM81 or 87 back door in replacement of the PM88 standard and back door
- Pneumatic model
- Pneumatic pendulum backstop (only compatible with PM87 back door)
- Weighing system

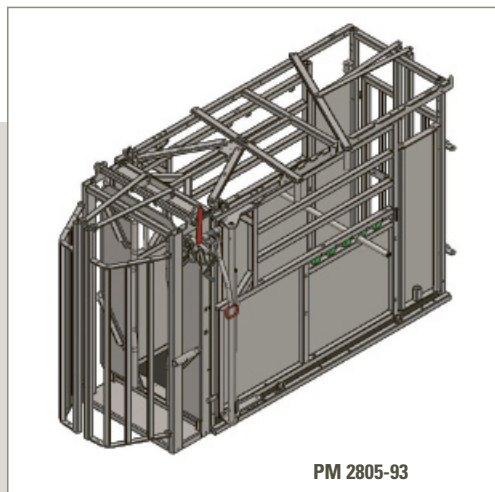
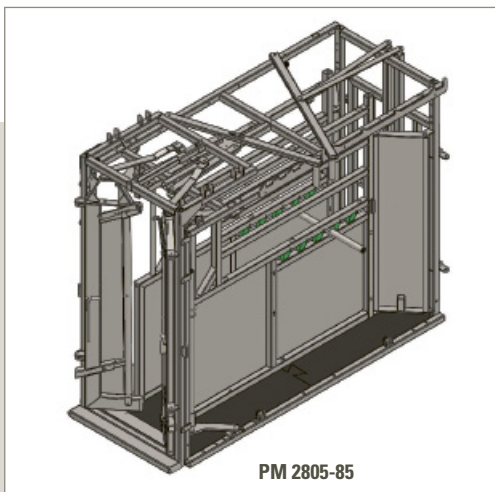

SQUEEZE CATTLE CHUTE PM 2810

>>> with reinforced hydraulic width reducer



Internal dimensions
length 270 cm
width 40 to 82 cm
height 170 cm

Gross weight: 750 kg

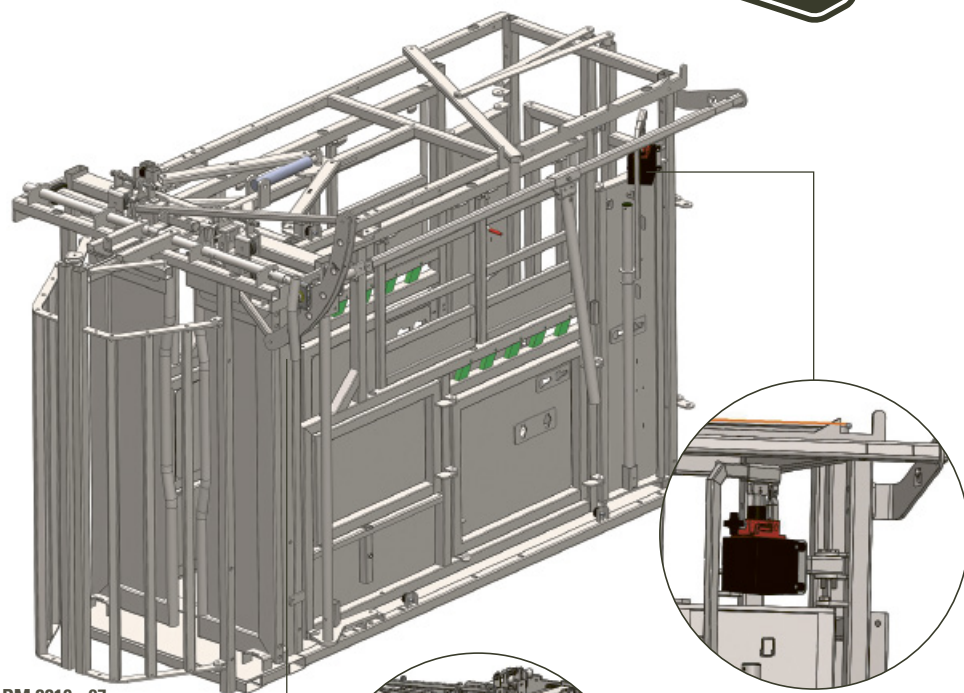

PM 2810 - 97

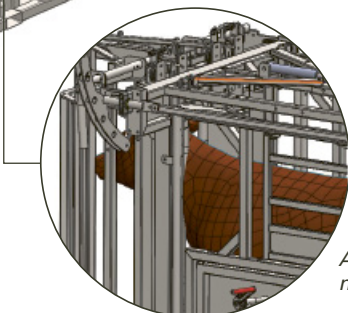

Hydraulic manual pump for width reducer

Access to animal's neck

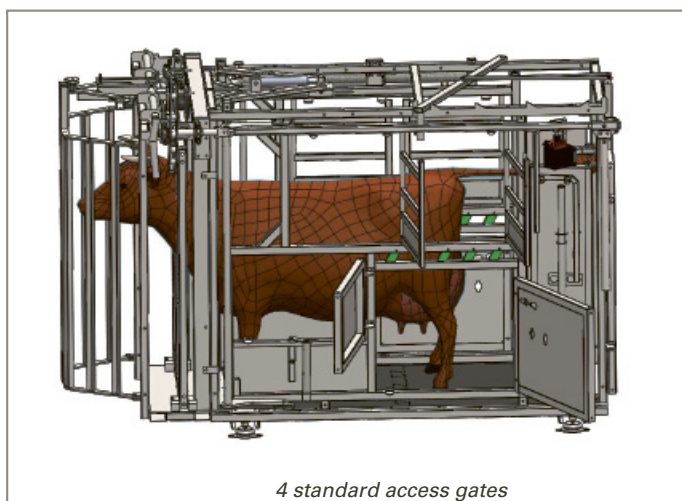

4 standard access gates

TECHNICAL FEATURES

- Headgate to choose from PM97, PM93 or PM85.
- Adjustable sides on width for all sizes of animal (from 42cm to 82 inside).
- Reinforced width reducer with hydraulic pump.
- Standard rubber mat, silent chute.
- Access to the animal's neck at the front of the crush for vaccination.
- High reversible side doors.
- Bottom side doors for access to the legs and udders of the animal.
- Back stop bar.
- Anti kick bar.
- Total immobilization of the animal.
- Save time, the animal cannot turn around in the chute.
- Work in total safety, a well-maintenance animal is a calmer animal.
- Product in paint of galvanised.

OPTIONS

Reverse model for crushes: handles on the left side for a front view

Manual SUPER model (hoof trimming equipment)

Electric SUPER model (hoof lifting with 1 motor)

Medicine box

Muzzle boom lift

Manual, pneumatic or hydraulic head lift

4 lifting brackets for transport

Forks passage

PM82, PM81 or 87 back door in replacement of the PM88 standard back door

Pneumatic model

Pneumatic pendulum backstop (only compatible with PM87 back door)

Weighing system (p.38)

ERGONOMIC SQUEEZE CATTLE CHUTE PM 2900



Overall dimensions

length 400 cm
width 175 cm
height 210 cm

Internal dimensions

length 375 cm
width 40 to 82 cm
height 180 cm

Gross weight

1200 kg

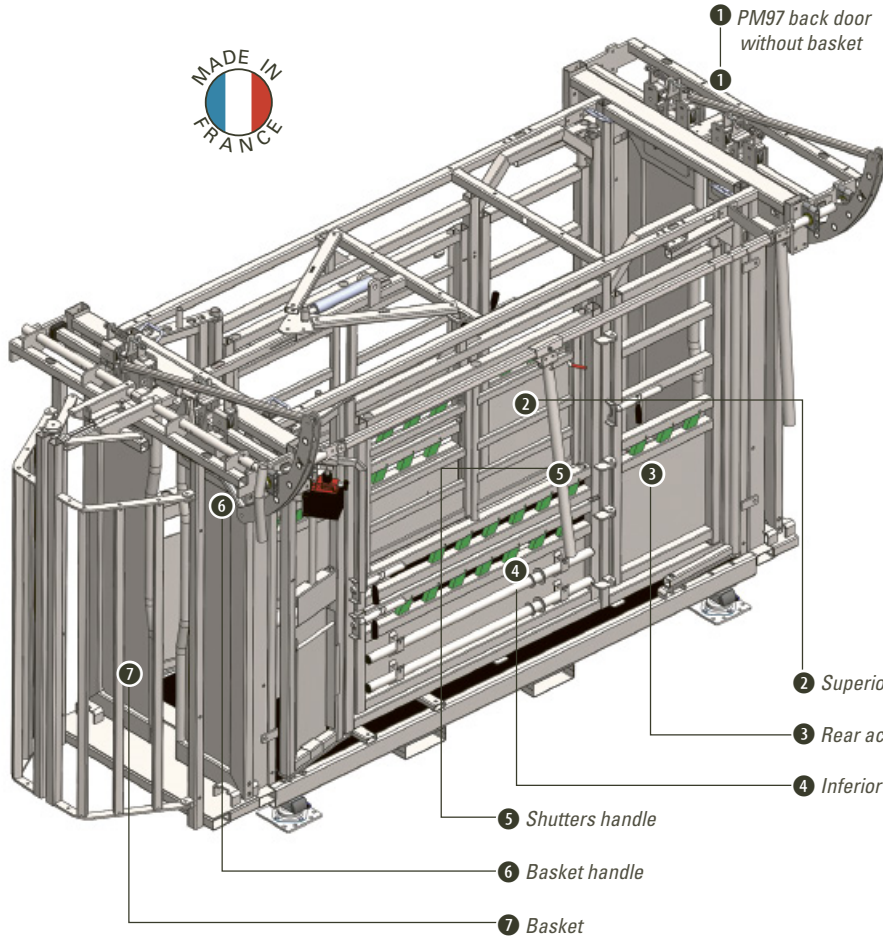

1 PM97 back door without basket

2 Superior access bar

3 Rear access door (man passage)

4 Inferior access

5 Shutters handle

6 Basket handle

7 Basket

TECHNICAL FEATURES

- Ergonomic crush, intuitive and silent, very easy to use.
- Multiple access for different interventions on the animal.
- Automatic front door with progressive tightening.
- Easy and flexible width reducer with hydraulic pump.
- Soundproof and non-slip rubber mat.
- Sternum bar which prevents the animal from lying down in chute.
- Full opening on the side of the crush.
- 1 backstop bar and 1 anti kick-bar.
- Man passage to cross and access behind the animal.
- Rear door with progressive tightening.
- Product only in galvanised.

OPTIONS

Sternum bar

Head lift

Weighing system (p.38)



ANIMAL COMFORT

- Silent crush.
- The animal feel safe when securely restrained.
- No risk of slipping.

USER BENEFITS

- Ergonomic.
- Light command for a better handling.
- Various access to the secured animal.

OPTIONS



MODÈLE SUPER ((Hoof trimming equipment)



Belly support



Rear legs winch



Front legs winch

GLUE AND CARE KIT for hooves



Include 1 x 200ml glue for hooves with 10x mixing canulas, 10x wooden blocks, 2x cohesive bandage, 1x hoof knife.

HEAD LIFT GALVA



Manual head lift

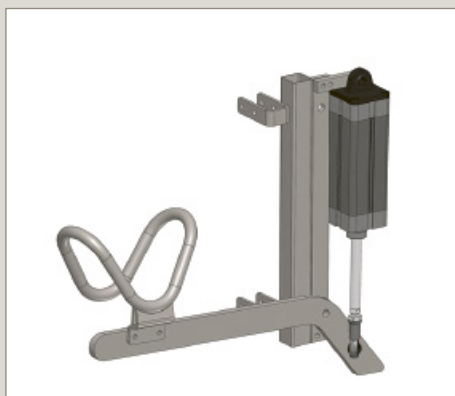

Pneumatic head lift

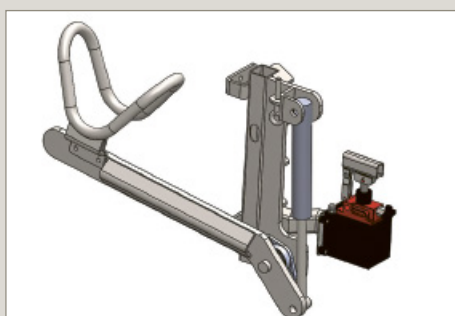

Hydraulic head lift

CRANCK rotating cranck with angle return



CRANK for ventral winch



MODEL SUPER (electric) Rotating arm with 1 electric hoist motor for trimming

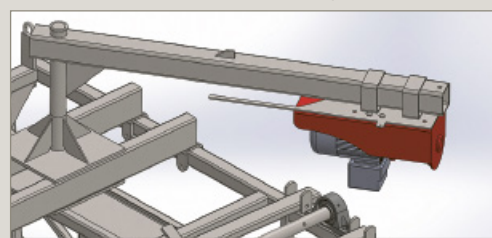

MUZZLE BOOM LIFT Galva

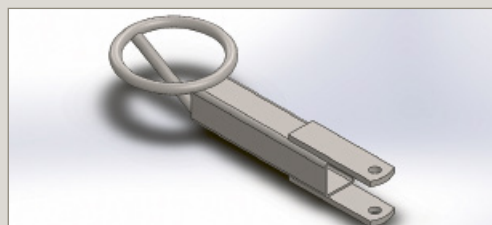

BGALVA STORAGE BOX Galva

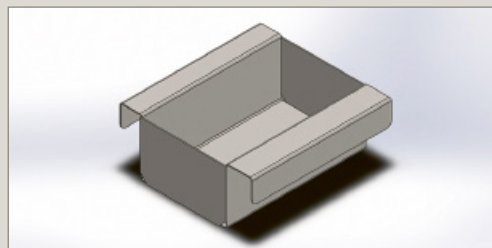

RUBBER MAT



WIDTH REDUCER
in 2 parts for PM 2400



CENTRAL STAKE
removable for PM 2400

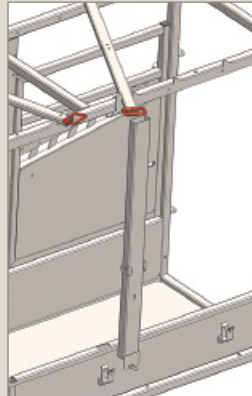

CAESAREAN DOOR
for PM 2400

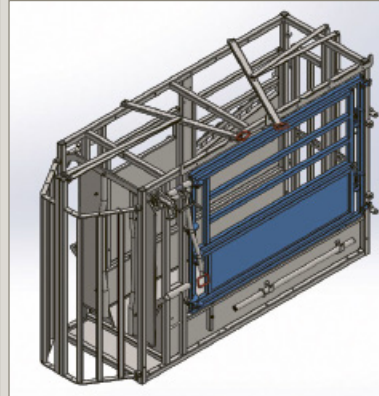
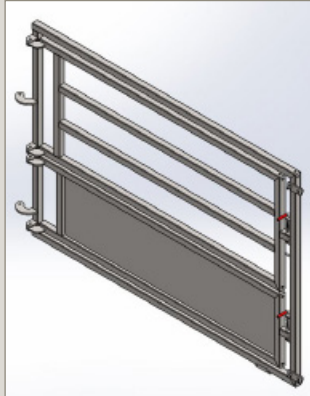

BACK DOOR
Sliding back door PM 81

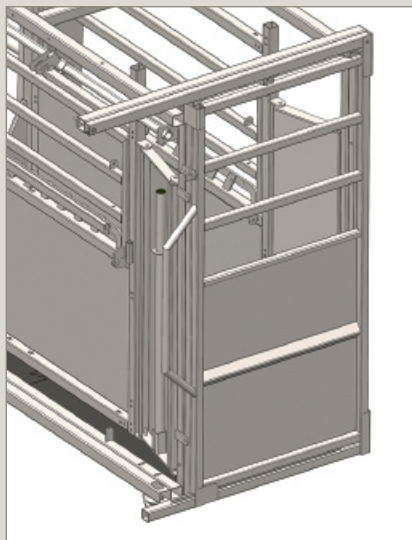

BACK DOOR
Insemination back door PM 82

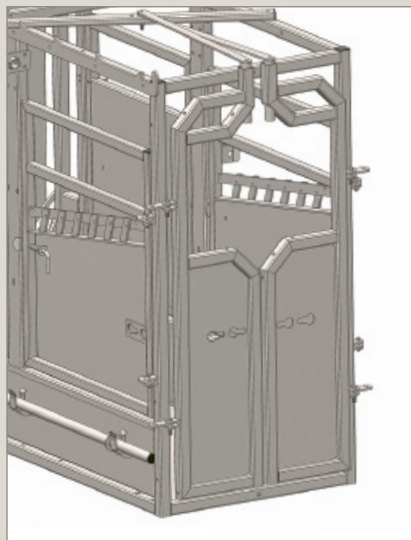

BACK DOOR
Sectional back door PM 87

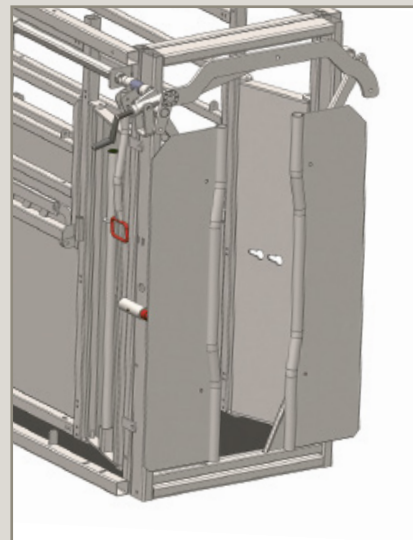

REVERSE MODEL
handles on the left side from a front view

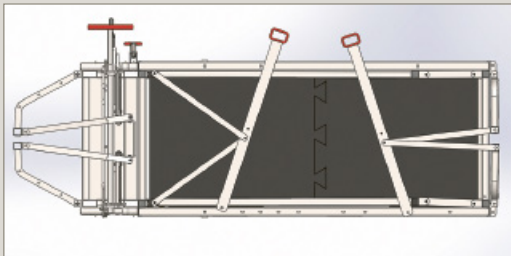

LIFTING EYEBOLT
for transportation

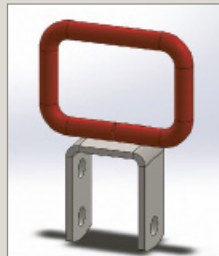

FORK
3 point-fork PM 30

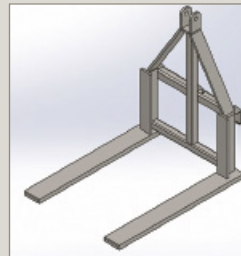

SET OF 4 BRACKETS
removable, for fixing fences

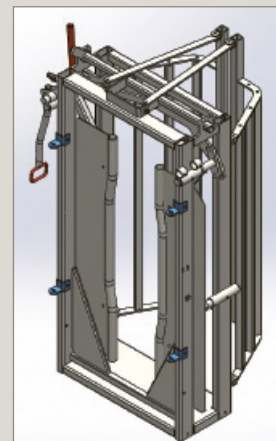

FORKS PASSAGE



REINFORCED HYDRAULIC PM 2855

>>> made for cattle trailers

Internal dimensions

length 264 cm
width 40 to 82 cm
height 180 cm

Gross weight: 1 500 kg

NEW

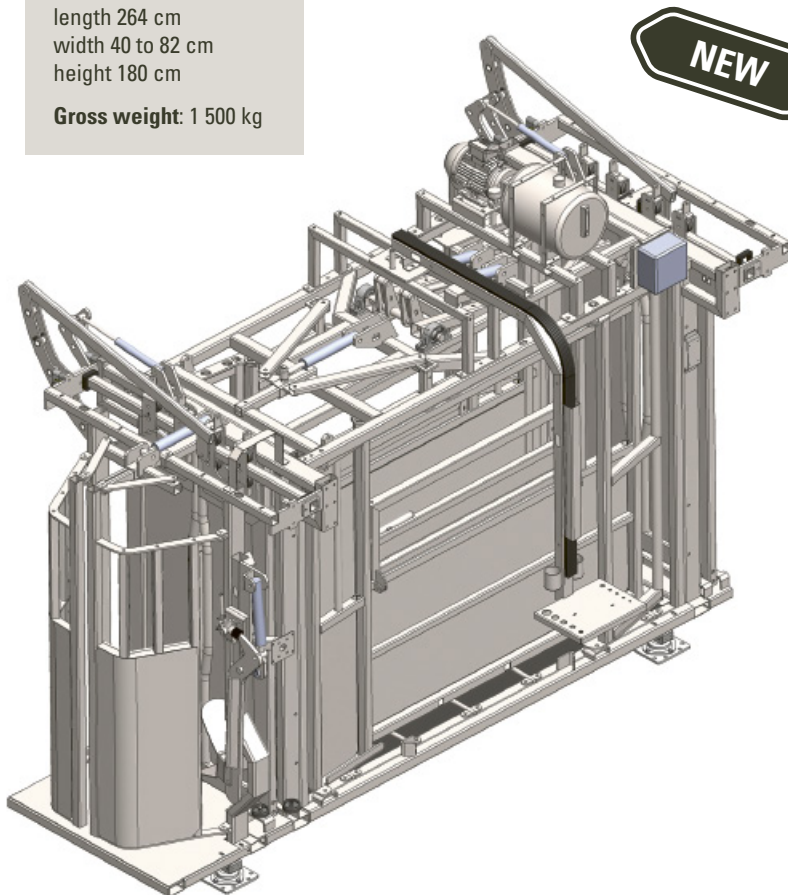

TECHNICAL FEATURES

- Reinforced hydraulic crush, specially designed for livestock trade.
- Reinforced model planned for more than 5000 animal passages for year.
- Head lift included reinforced in pneumatic or hydraulic.
- Pendulum backstop included reinforced in pneumatic or hydraulic.
- Folding top flat for access to the animal's back.
- Soundproof rubber mat with non-slip reinforcement bars.
- Ideal for all types of prophylaxis.

HYDRAULIC

TECHNICAL FEATURES

- Hydraulic unit included with 30 liter oil tank. 220V mono 16A power cable.
- Working time: 5 hours/ Resting time: 1 hour and a half.
- Electrical panel and 30mA protection.
- Emergency stop, on/off button. 5 hydraulic functions to maneuver the safety basket, front door, width reducer, pendulum backstop and rear door.

ÉLECTRO-PNEUMATIC

TECHNICAL FEATURES

- Electro-pneumatic system with remote control, control the opening and closing of the basket, front door, width reducer, pendulum backstop and rear door.
- 220V electrical connection needed.
- Compressed air connection with air dryer needed.

OPTIONS

Add weighing system (p.38)

HYDRAULIC PM 2900



Internal dimensions

length 375 cm
width 40 to 82 cm
height 180 cm

Gross weight: 1200 kg



TECHNICAL FEATURES

- Hydraulic chute, silent and very easy to use.
- Hydraulic unit included with 30 liter oil tank.
- 220V mono 16A power cable.
- Working time: 5 hours / Resting time: 1 hour and a half.
- Electrical board and 30mA protection.
- Emergency stop on/off button.
- 4 hydraulic functions to operate the safety basket, the front door, width reducer, rear door.
- Many accesses on the side for different interventions on the animal.
- Total opening on the side of the cage.
- Soundproof and non-slip rubber mat.
- Sternum bar that prevent the animal from lying down in the chute.
- 1 backstop bar and anti-kick bar.
- Man access to cross and reach behind the animal.

OPTIONS

Manual head lift

Hydraulic head lift with manual pump

Head lift on hydraulic connection

Weighing system (p.38)



PNEUMATIC AUTOMATION



1ST POSSIBILITY

Pneumatic cylinders controlled by distributors on a fixed support, or on a swivel bracket on the whole side of the crush.



Fixed support with 1 joystick



Swivel bracket

2ND POSSIBILITY

Electro-pneumatic cylinders with control box and remote control to activate doors and options from a distance.



Control box



Remote control

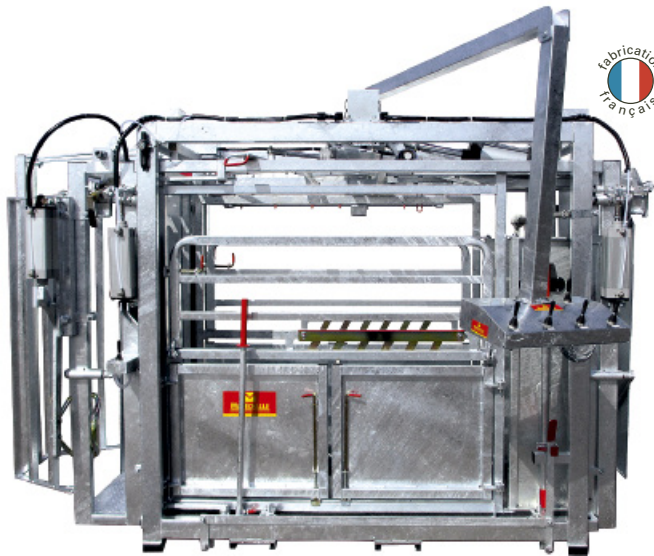

PRODUCT ADVANTAGES AND BENEFITS

- Ideal for passing many animals.
- Pneumatic cylinders replacing the manual handles to control doors' openings and closings.
- The cylinders also control width reducer of the crush PM 2800, and other options as scoop head up and pendulum backstop.
- System allowing the user to position away, so the animal is not frightened by the presence of humans.
- Rapidity and work comfort, avoids repetitive movements and musculoskeletal disorders.
- Quiet system, the animal remains quiet and well-maintained.
- Time saving and better productivity for the farmer, and less fatigue for the user.

TECHNICAL FEATURES

- Connection to an air compressor (not supplied) of at least 200 liters.
- Working pressure: 6 bars.
- Flow control to accelerate or slow down the doors' opening and closing.

Our advice: the compressor must be within 30 m of the crush, or be equipped with an air dryer.

CALVES DEHORNING BOX PM 170



Internal dimensions

length 110 cm
width 40 cm
height 108 cm

Gross weight: 110 kg



TECHNICAL FEATURES

- Total immobilization of the animal.
- Good hold on the calf.
- Dehorn different sizes of calves.
- Easily transportable, offers high stability and good resistance.
- Rubber mat.

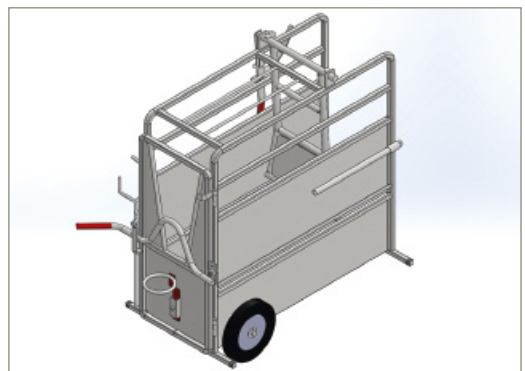

ANIMAL COMFORT

- Without noise, keep calves calm.
- Well-maintained in the crate, the animal feels safe.
- No risk of slipping or hanging.

USER BENEFITS

- Time saving and productivity, the dehorning can be done by only one person.
- Work safely.

PORTABLE HANDLING ALLEY PM 3200



Internal dimensions

length 650 cm
width 82 cm
height 170 cm

Weight: 950 kg



TECHNICAL FEATURES

- Designed to do all treatments outside.
- Not approved for traveling on public roads besides France's road.
- Front of the alley equipped with a handling crush type PM2400.
- Headgate can be either PM 83 or PM97.
- Avoids the use on footboard.
- Reducer in width preventing the calves from overturning.
- Easy entry thanks to the rear side doors.
- The animal enters the alley better because it follows the other animals (up to 3 animals).
- Transport of 16 panels possible thanks to the 2 sliding tubes.
- PM 88 double-leaf rear door.
- Traffic lights.
- Possibility of inserting a weighing platform.

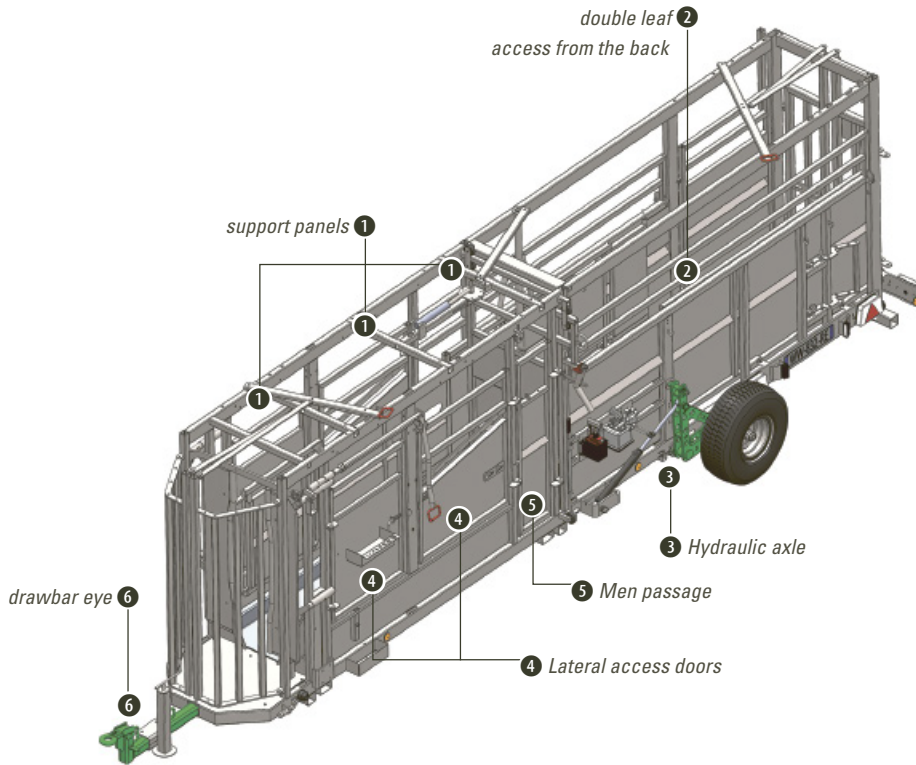

OPTIONS
Reverse model: handles on the left from a front view
SUPER model: hoof trimming equipment
Manual heel lift
Rubber mat
Muzzle boom lift
PM 42 weighing platform + indicator

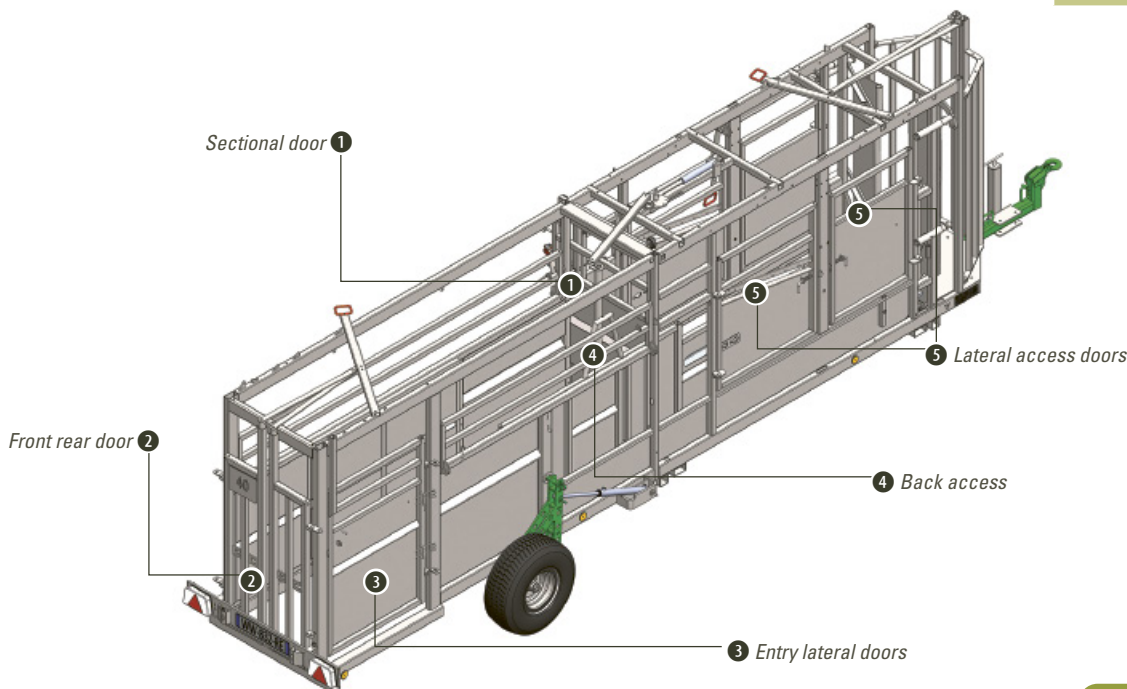

WATCH
OUR VIDEOS ON 

www.marechalle-pesage.com

TRAILER TRAY PM 1030 T

>>> Transport and use our crushes



TECHNICAL FEATURES

- Trailer permit required.
- Trailer tray able to support our handling, hoof trimming and weighing crushes.
- Trailer approved for registration and road transport only in Europe.
- The tray placed completely on the ground avoids a step too high and allows animals to crush more easily.
- Thereby, you save time in interventions (treatments, weighing, hoof trimming, etc.).

OPTION

Electric pump for the 4 hydraulic cylinders

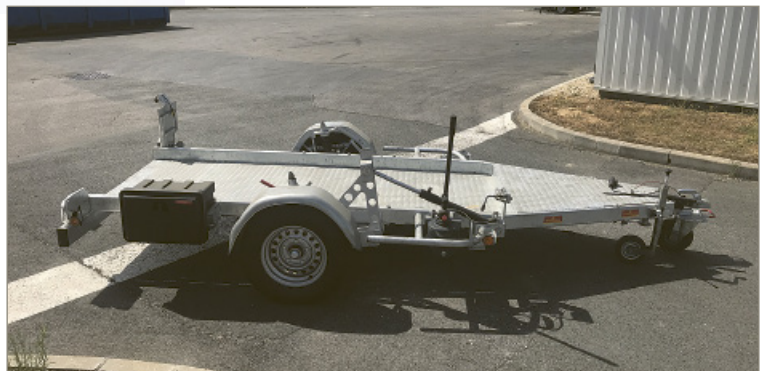
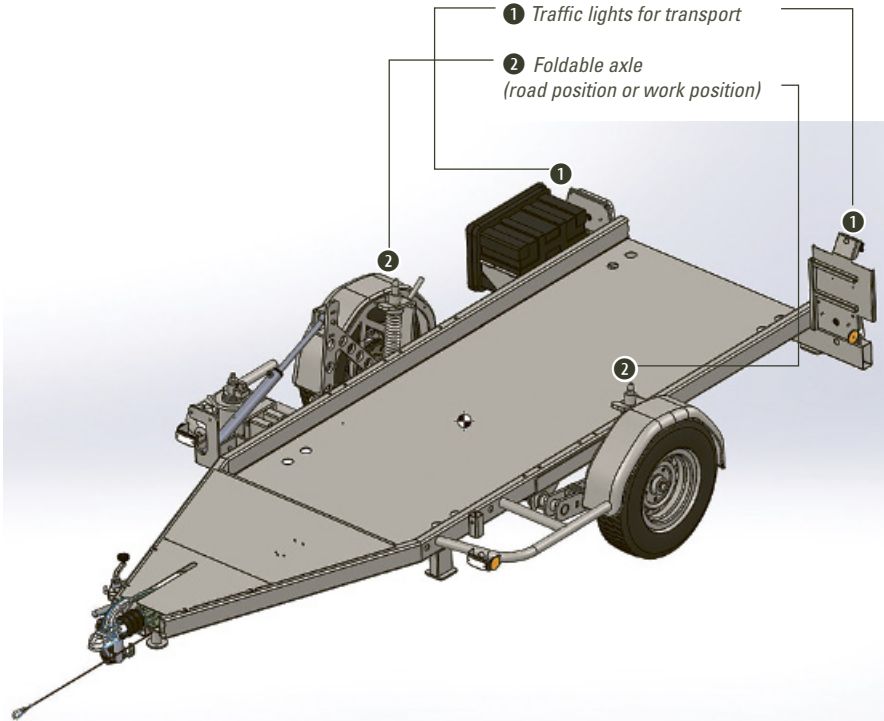

with PM 2800 crush



with PM 4600 crush

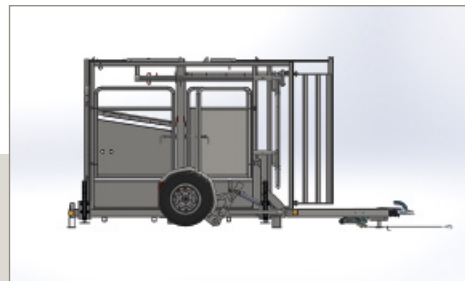

with PM 2400 crush

PRODUCT BENEFIT

- The trailer tray allows you to move from farm to farm.

HOOF TRIMMING

GET A HOOF TRIMMING CRUSH IN ORDER TO TREAT FASTER !



- Trimming is an important and effective care to apprehend limping, which today represents the cattle's third pathology.
- Trimming claws preventively prevent limping.
- A poorly treated or late treated limping can result in a significant financial loss to the herds (decreases production, growth retardation, delayed reproduction, veterinary costs, ect.). This is why we must act quickly on a painful leg.
- A hoof trimming crush is therefor essential to work safely and provide the necessary care for your animal while facilitating work.

Decrease limpings,
is to increase your profits !



SLIDE-OVER TREATMENT CRUSH PM 4200



Internal dimensions

length 205 cm
width 82 cm
height 175 cm

Gross weight: 185 kg
(with front winches)



TECHNICAL FEATURES

- Light crush.
- Reinforced frame.
- Easy to move with wheels to be able to bring to the self locks.
- Easy handling, the animal is less stressed.
- Hoof trimming for front legs possible with option of wood supports with rope.
- Product galvanized only.

OPTIONS

2 curved wood supports with ropes for front legs hoof trimming

Medicine box

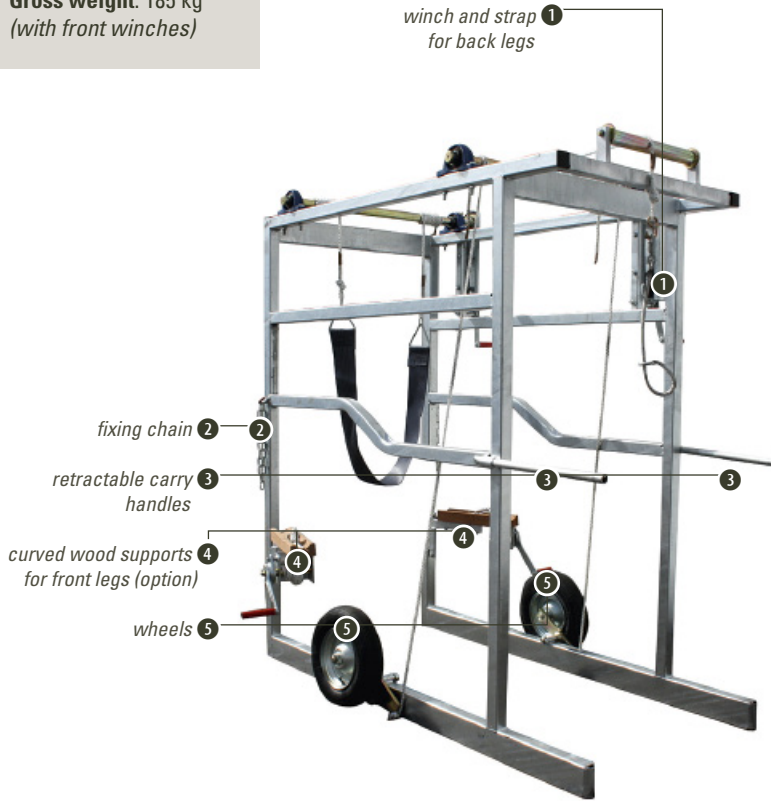

USER BENEFITS

- Time saving.
- Total immobilization of the animal.
- Work safety by only one person.
- Easy to handle.

MANUAL HOOF TRIMMING CRUSH PM 4300



Internal dimensions
length 190 cm
width 82 cm
height 175 cm

Gross weight: 350 kg

TECHNICAL FEATURES

- Auto-locking front door PM 85 with adjustable width of the shutters.
- Wide and curved support for front legs for good posture and total immobilization.
- Automatic pendulum backstop system, immobilizing the animal.
- Soundproof and anti-slipping rubber mat.
- Ground attachments.
- Product galvanized only.

HOOF TRIMMING

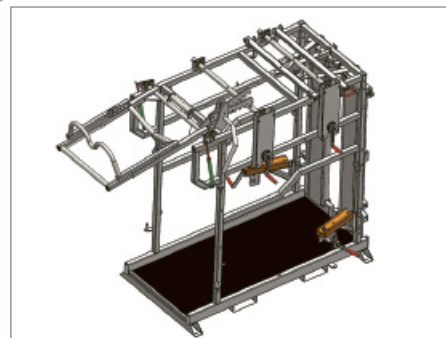
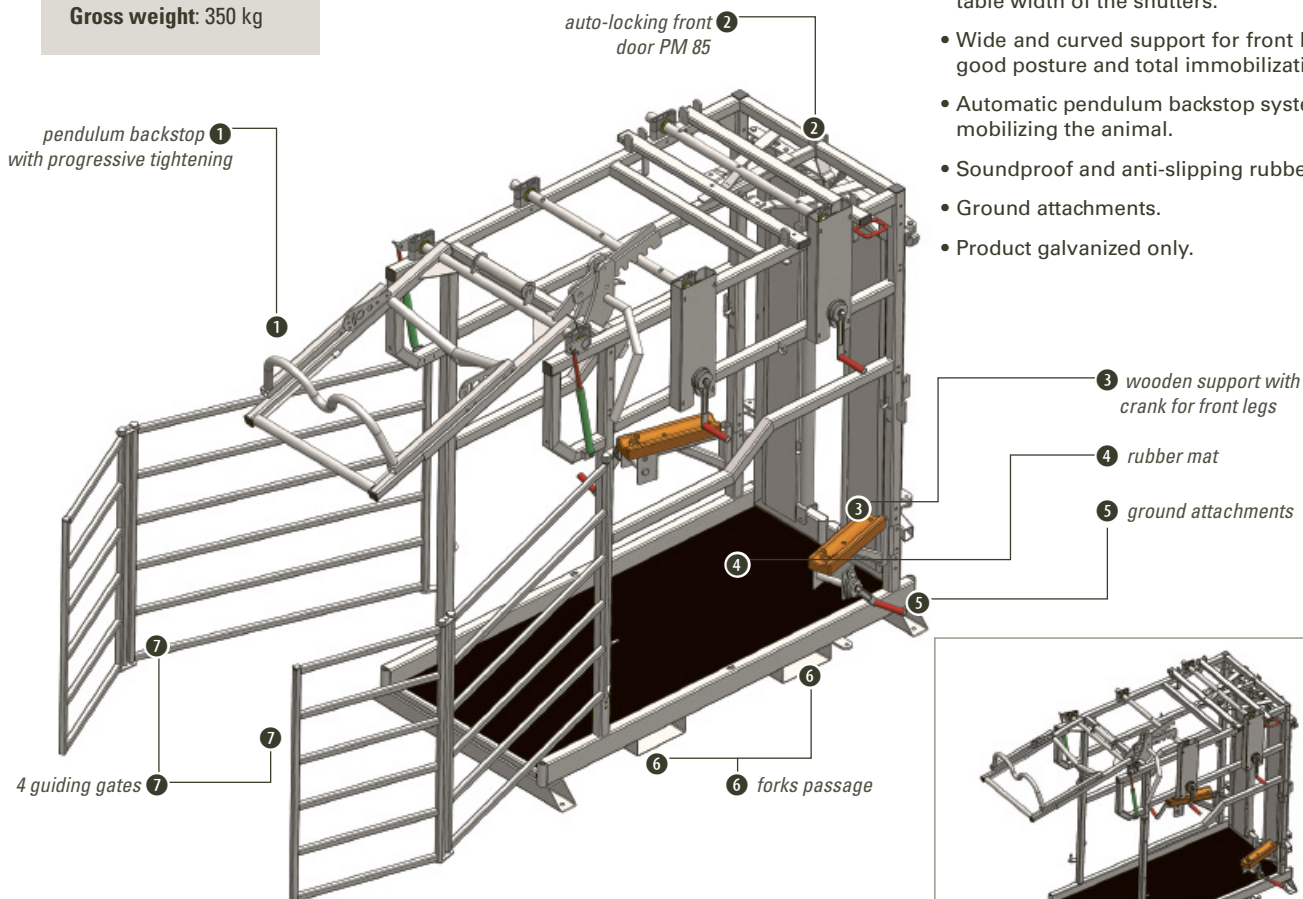

ANIMAL COMFORT

- Fast handling, the animal is less stressed.
- Rubber carpet 20 mm thick, limiting noise and slips.

USER BENEFITS

- Hoof trimming less tiring because no effort to lift the animal's feet.
- Better protection of the farmer with pendulum backstop.
- Total immobilization of the animal, easy grip of the shank.
- Work in total safety by one person only.

OPTIONS

- Galva Medicine box
- Glue and care kit for hooves
- Anti-backstop specific for White-Blue-Beige breed
- Three-points forks PM 30



ELECTRIC HOOF TRIMMING CRUSH WITH 1 MOTOR PM4400

>>> for frequent trimming from 30 cows

Internal dimensions

length 190 cm
width 82 cm
height 180 cm

Gross weight: 500 kg

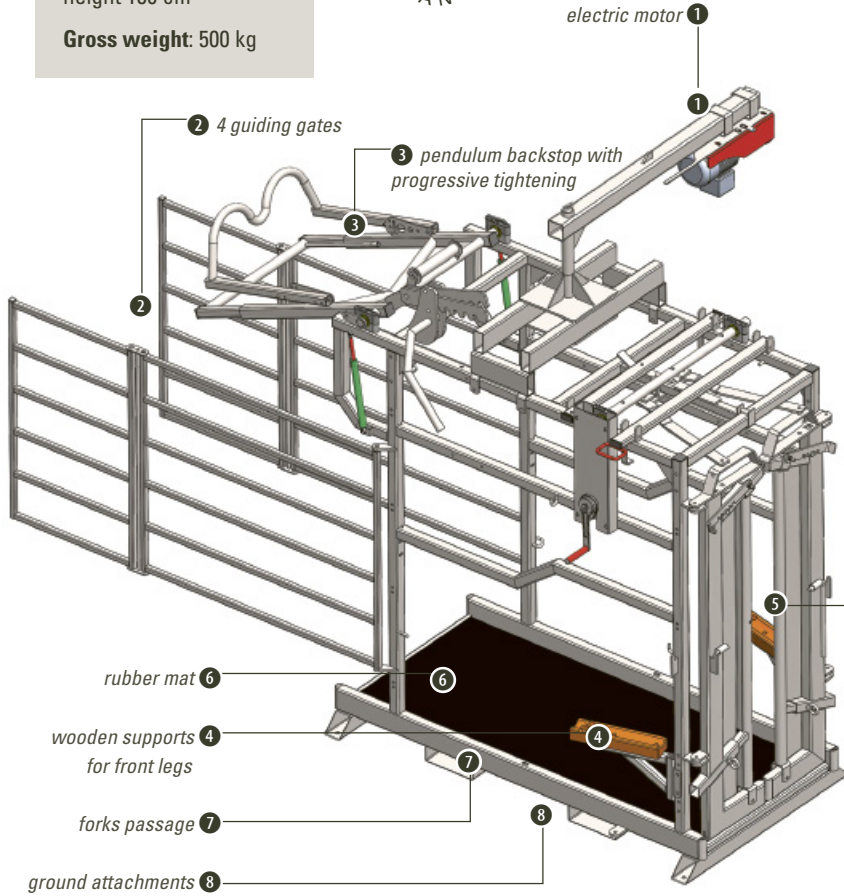

TECHNICAL FEATURES

- 1 electric motor on rotating arm to lift front and back legs effortlessly.
- Auto-locking front door PM 85 with adjustable width of the shutters.
- Wide and curved support for front legs for good posture and total immobilization.
- Automatic pendulum backstop system, immobilizing the animal.
- 1 ventral strap with manual winch to hold the animal.
- Soundproof and anti-slipping rubber mat.
- Ground attachments.
- Product galvanized only.

OPTIONS

Galva Medicine box

Glue and care kit for hooves

Anti-backstop specific for White-Blue-Beige breed

Three-points forks PM 30



ANIMAL COMFORT

- Fast handling, the animal is less stressed.
- Rubber carpet 20 mm thick, limiting noise and slips.

USER BENEFITS

- Hoof trimming less tiring because no effort to lift the animal's legs.
- Better protection of the farmer with pendulum anti-backing.
- Total immobilization of the animal, easy grip of the shank.
- Work in total safety and by one person only.

ELECTRIC HOOF TRIMMING CRUSH WITH 1 MOTOR PM 4450

>>> with lateral doors

Internal dimensions

length 190 cm
width 82 cm
height 180 cm

Gross weight: 590 kg



HOOF TRIMMING

TECHNICAL FEATURES

- 1 electric motor on rotating arm to lift front and back legs effortlessly.
- Auto-locking front door PM 85 with adjustable width of the shutters.
- Wide and curved supports for front legs for good posture and total immobilization.
- Aluminium hook to lift the back legs.
- Manual pendulum backstop immobilizing the animal.
- 1 ventral strap with manual winch to hold the animal.
- 6 lateral doors.
- Soundproof and anti-slipping rubber mat.
- Ground attachments.
- Product galvanized only.

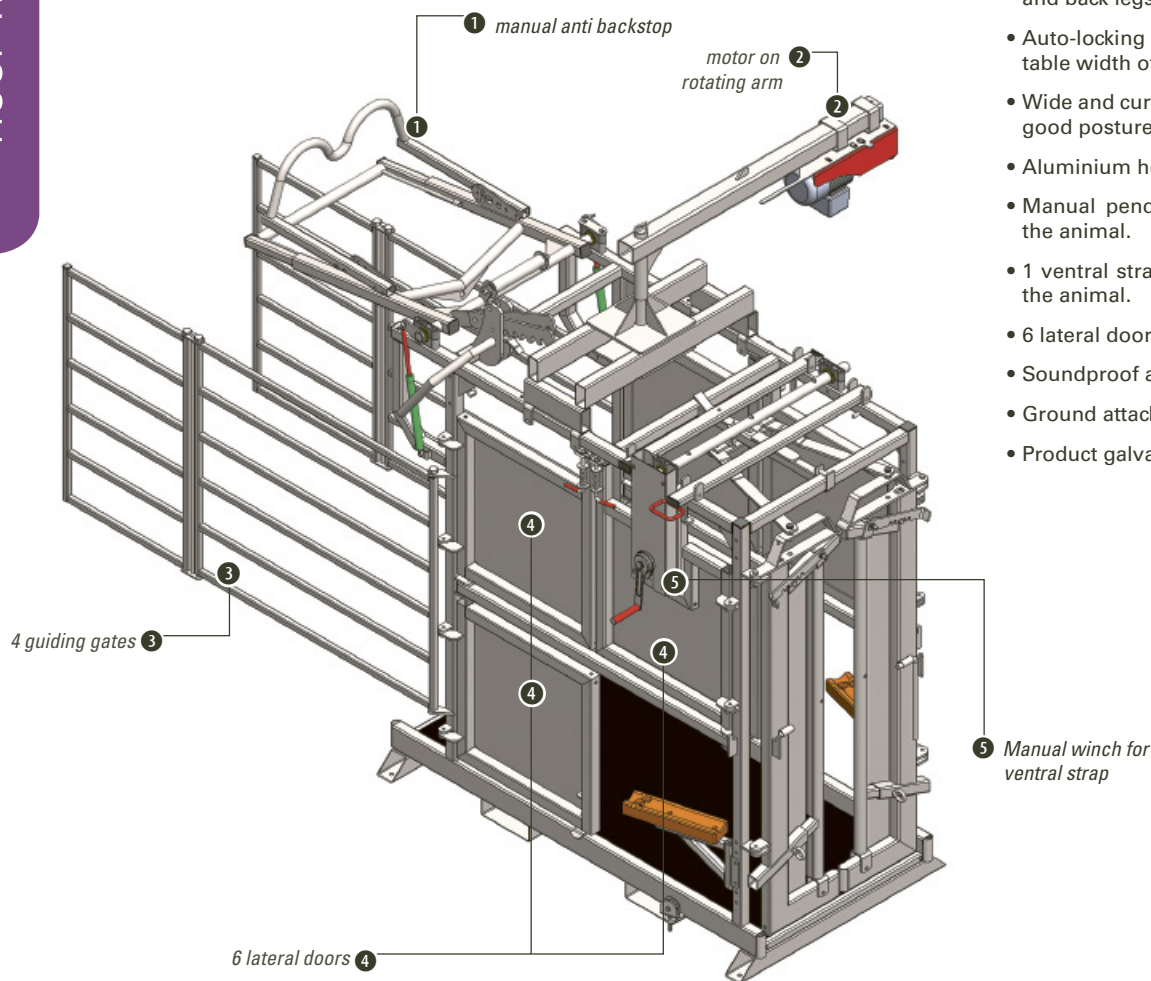

ANIMAL COMFORT

- Fast handling, the animal is less stressed.
- Rubber carpet 20 mm thick, limiting noise and slips.

USER BENEFITS

- Hoof trimming is less tiring because no effort is needed to lift the animal's feet.
- Better protection of the farmer with pendulum anti-backing.
- Total immobilization of the animal, easy grip of the shank.
- Work in total safety and by one person only.

OPTIONS

- Galva medicine box
- Glue and care kit for hooves
- Backstop specially made for Belgian blue cattle
- Three-points forks PM 30



ELECTRIC HOOF TRIMMING CRUSH WITH 6 MOTORS PM 4600

>>> for frequent trimming and cares from 40 cows

Internal dimensions

length 190 cm
width 82 cm
height 180 cm

Gross weight: 620 kg



Pneumatic pendulum back stop 1

rotating bracket with spot and electrical outlet 2



4 guiding gates 10

electric controls for front legs supports 3

auto-locking front door PM 85 4

access doors for caesarean section and surgical operations 5

wide wooden supports for front legs 6

rubber mat 7

forks passage 8

ground attachments 9

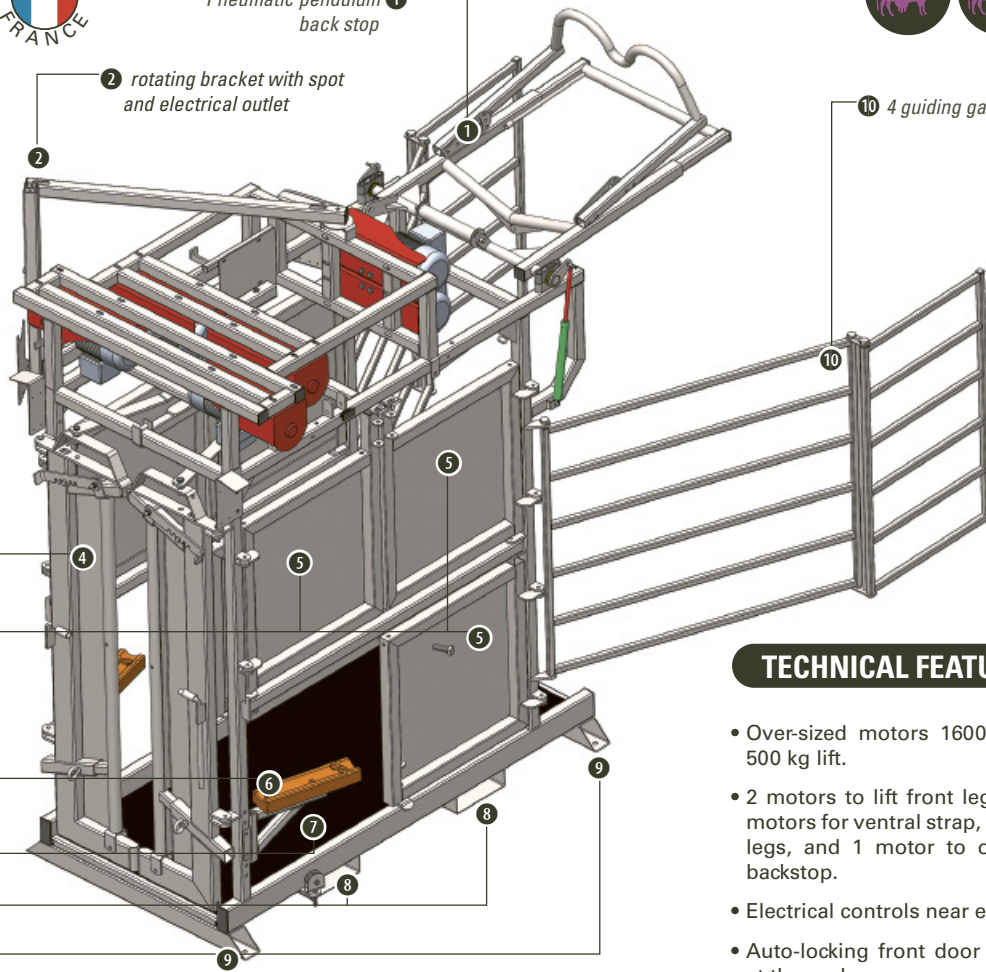

TECHNICAL FEATURES

- Over-sized motors 1600 Watts/motor and 500 kg lift.
- 2 motors to lift front legs on each side, 2 motors for ventral strap, 1 motor to lift back legs, and 1 motor to operate pendulum backstop.
- Electrical controls near each workstation.
- Auto-locking front door PM 85 adjustable at the neck.
- Wide and curved front leg supports allowing good hold of the leg.
- Guides for back legs to hold them on the backstop.
- Connection 220 V.
- Electrical outlets and spotlight.
- Product galvanized only.



ANIMAL COMFORT

- Fast handling, the animal is less stressed.
- Rubber carpet 20 mm thick, limiting noise and slips.

USER BENEFITS

- Hoof trimming is less tiring because no effort is required to lift the animal's feet.
- Time saving with electric motors.
- Better protection of the farmer with pendulum backstop.
- Total immobilization of the animal, easy grip of the shank.
- Work in total safety and by one person only.
- Better techno-economic results, less trimmer costs.

OPTIONS

- Galva medicine box
- Glue and care kit for hooves
- Backstop specially made for Belgian blue cattle
- Three-points forks PM 30



HYDRAULIC HOOFTRIMMING CRUSH PM4700

>>> For dairy and beef cattle



HOOF TRIMMING

Internal dimensions

length 190 cm
width 82 cm
height 180 cm

Gross weight: 1 100 kg

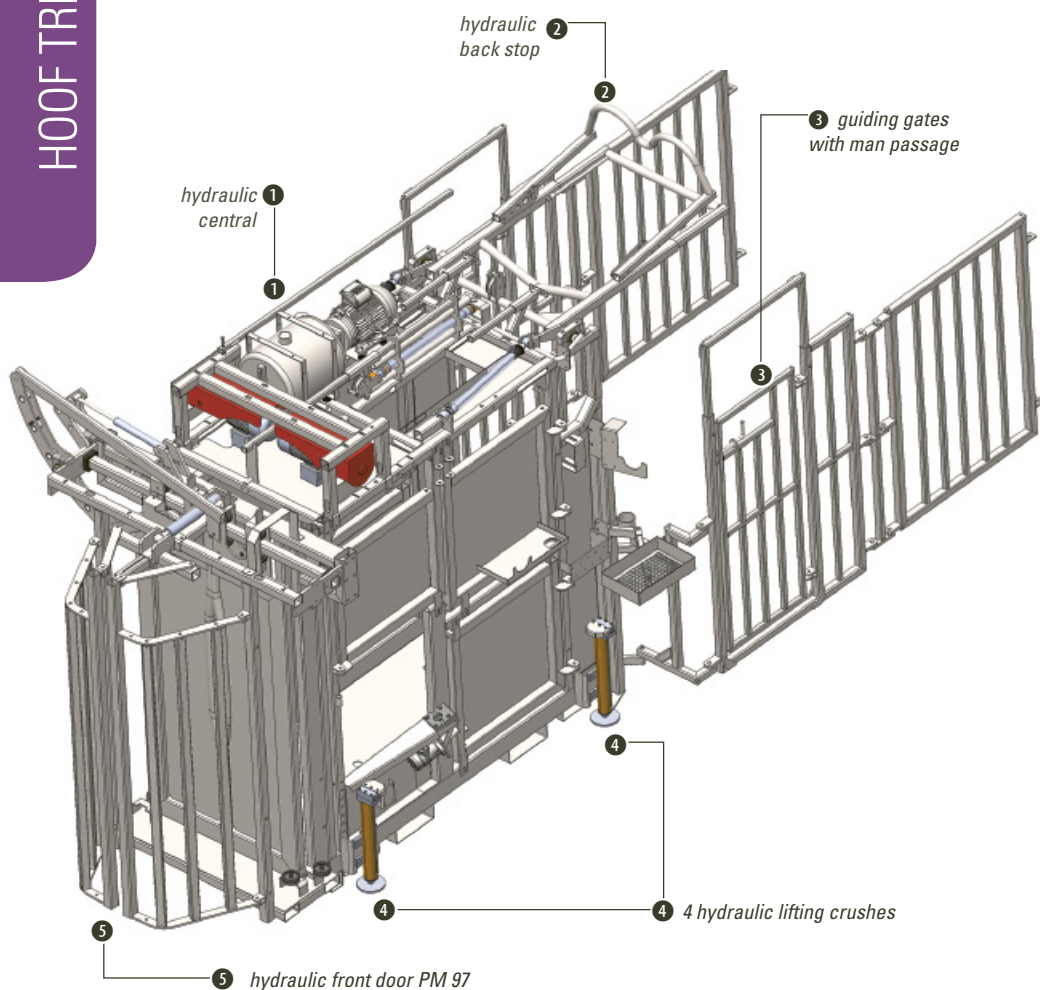

TECHNICAL FEATURES

- Crush designed for farmers and developed with professional veterinarians-trimmers for dairy and beef cattle.
- Hydraulic unit included with 30 liter oil tank.
- 220V mono 32A power cable with bracket to deport the power cable.
- 2x 220V sockets on both sides of the crush.
- Working time: 5 hours / Resting time: 1 hour and a half.
- Electric board and 30mA protection. The functions are unlockable in the event of a power failure.
- 4 hydraulic crutches to lift the crush by 30 cm and be able to work at the right height.
- Hydraulic controls on both sides of the crush for basket, front door, fliting crutches, backstop and rear leg lifter.
- Hydraulic front leg support with guide wall and hook to catch the leg quickly and safely.
- Spotlight for front legs on each side.
- Electrical ventral strap with control on each side of the crush.
- Hydraulic backstop with double hoop.
- 2 spotlight for back legs.
- Aluminium hook for quickly and safely catching the back leg.
- 3 side access doors on each side of the crush.
- Support for grinders.
- Storage baskets for care products.
- Spot for paper dispenser.
- Rubber mat.
- Forks passage.
- Galvanized product only.

OPTIONS

Hydraulic head lift

Glue and care kit for hooves

Barrier with folding man passage inside the cage (incompatible with weighing)

Weighing system (incompatible with barriers)



WATCH
OUR VIDEOS ON



www.marechalle-pesage.com

TREATMENT BOX FOR HORSES PM 2007



Internal dimensions

length 220 cm
width 82 cm or 92 cm
height 220 cm

Gross weight: 270 kg



TECHNICAL FEATURES

- Designed for hoof trimming and other treatments for horses.
- Good stability and good hold of the animal.
- Control, care, treat hooves.
- Shoeing horses.
- Product available in paint or galvanized.

OPTION

Medicine box

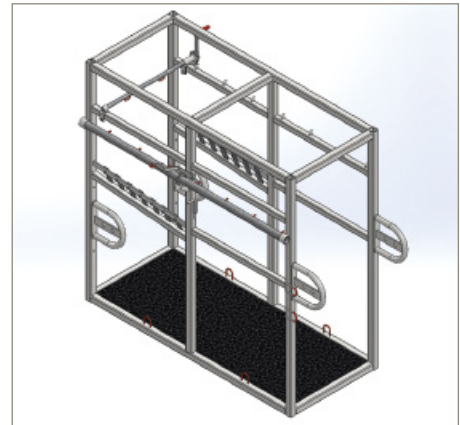

ANIMAL COMFORT

- Good stability on 3 with ventral support.
- Sound absorbing and anti-slip rubber mat, keeps the animal calm and prevent slips.

USER BENEFITS

- Time saving.
- Work safety.

IDENTIFICATION

ELECTRONIC IDENTIFICATION WITHIN EVERYONE'S REACH



- Identify your animals with electronic tags readers and find the history of their cares or weights in few seconds.
- Pair a weighing system with an identification system to allow you to sort more simply and more quickly your animals.
- Follow up in live your animals' informations on your smartphone thanks to devices equipped with Bluetooth.

Computerize data and
optimize your time !



ELECTRONIC EAR TAGS



IDENTIFICATION



TECHNICAL FEATURES

- HDX technology RFID ear tag conforms to ISO 11784-11785 standards.
- Female part: HP Ultra HDX electronic button.
- Male part: male button.
- Tensile strength of couple male/female before rutpure > 300 N.
- Thermoplastic polyurethane elastomer containing a laser marking agent and a food colorant.
- Head of the female buckle is polyamide.
- The male part's bole tip consists of a sharp insert in ZAMACK covered with a protective layer of zinc.

STICKS READERS XRS2



Dimension
length 65,6 cm
weight: 706 g

WATCH
OUR VIDEOS ON



www.marechalle-pesage.com

stick reader XRS2

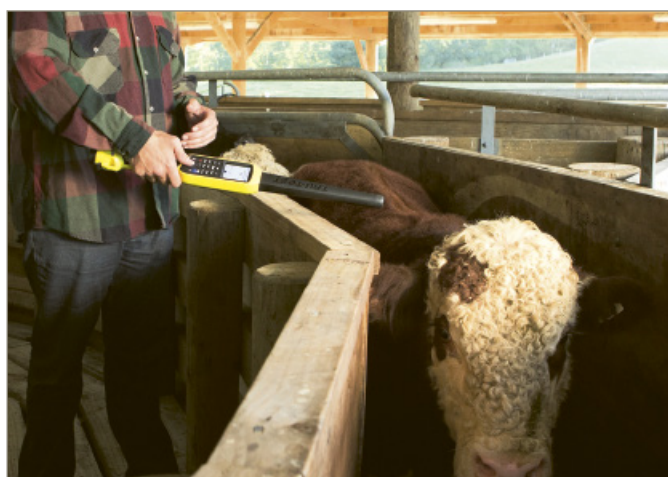

TECHNICAL FEATURES

- Reads all ISO HDX and ISO FDX-B tags.
- Rugged design, proven for the tough agricultural environment with a IP67 waterproof design.
- Long life battery up to 19 hours, charging in 3 hours.
- Built-in Bluetooth and auto coupling.
- USB port.
- Capture up to 15 pieces of customized information for each animal, such as breed, sex, DOB and condition score.
- Large sunlight viewable colour LCD screen and alphanumeric keypad.
- Stores up to 1 million scanned tag memory in 250 sessions.
- Rapid reading of tags with feedback through vibrating handle.

EID PANEL READERS

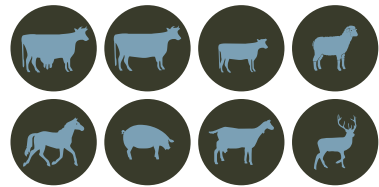

Dimensions large antenna
width 603 mm
height 873 mm
depth 15/38 mm
Weight: 8,5 kg

Dimensions small antenna
width 400 mm
height 425 mm
depth 10/33 mm
Weight: 2,5 kg



www.marechalle-pesage.com

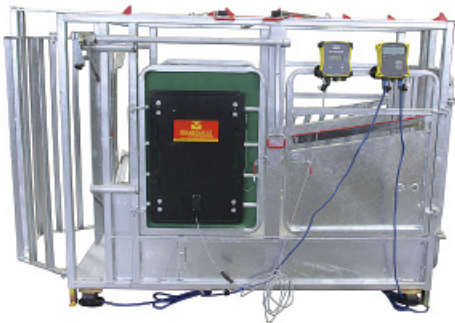

IDENTIFICATION

TECHNICAL FEATURES

- Reads all ISO HDX and FDX-B ear tags.
- Comes with Data Link PC software for Windows, for downloading recorded information and configuring the reader.
- Clear and bright display even in bright sunlight, and buzzer when information is read.
- Option to record tags or send to your weigh scale indicator.
- Data Link app for Android smartphones, email session files back to the office.
- Rugged design and easy to install.
- Bluetooth Class 1 wireless technology to transfer scanned EIDs to weigh scale indicator or other devices up to 100 m away. Automatic pairing/connection to Tru-Test weigh scale indicator, or use the supplied serial communication cable.
- Superior read performance:
 - FDX: Up to 1,000 reads per minute
 - HDX: Up to 850 reads per minute
- Either connect to a 12-24 V battery or use the supplied mains power adaptor.
- Record scanned tags into session files that can be downloaded. Store up to 20,000 tags in memory.
- Read distance up to 1 m for large antenna and up to 700 mm for small antenna.
- IP67 waterproof case with double walled construction and rubber corner buffers for extra durability.

BARCODE SCANNER



Dimensions
 height 18,5 cm
 length 75 cm
 depth 14,2 cm
Weight: 385 g



charging base

IDENTIFICATION

TECHNICAL FEATURES

- Scanner, barcode ear tags reader.
- Built-in Bluetooth to communicate with the weighing indicator.
- Compatible with ID / XR 3000, ID / XR 5000, I 40 and I 45 indicators.
- Superior performance in reading 1D barcodes, regardless of their state.
- Rugged design and IP67 protection.
- Designed to withstand extreme cold, heat and humidity.
- Accessories included: base, power supply and USB cable.

MARÉCHALLE SOFTWARE

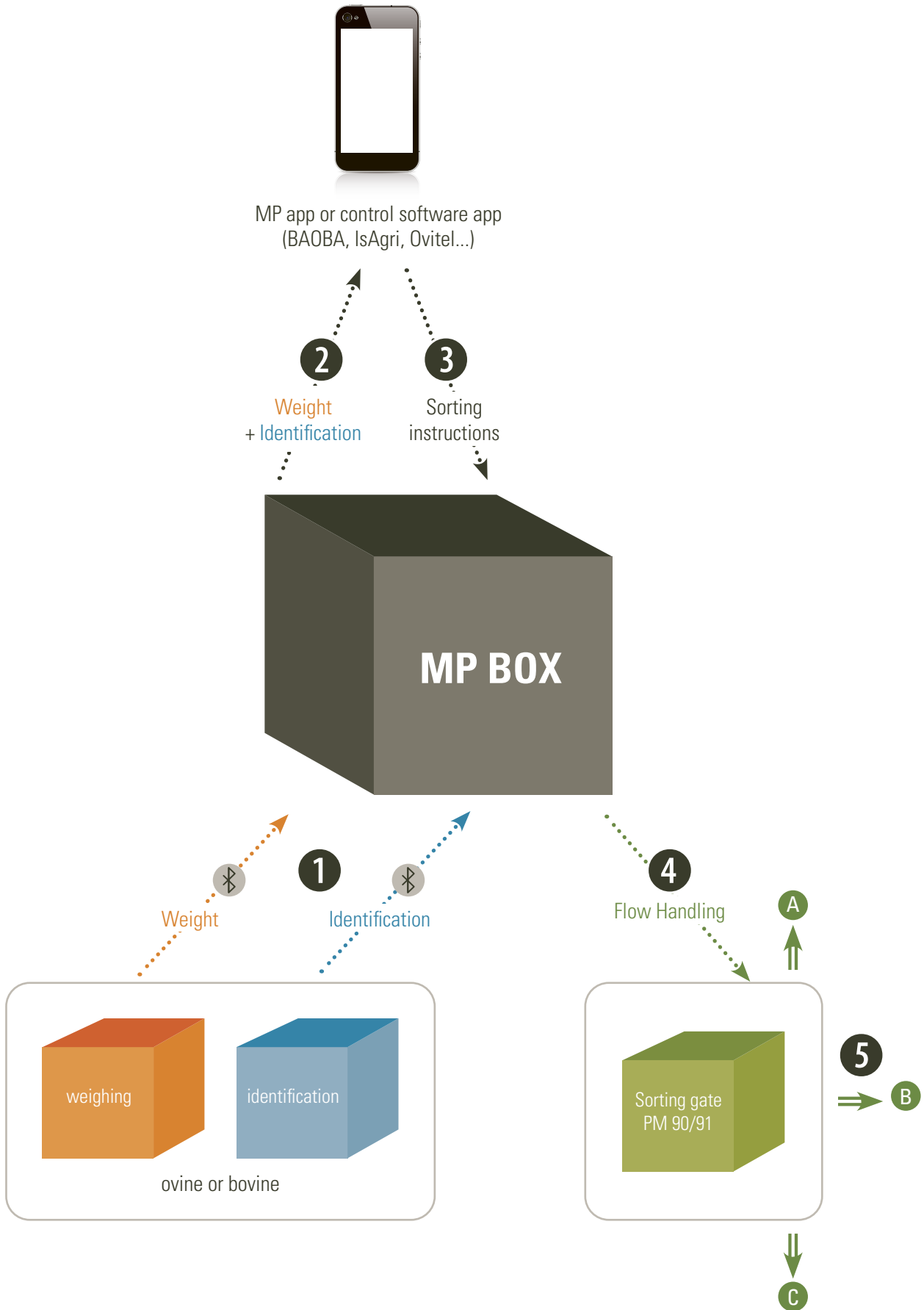



WEIGHING

WEIGH TO WIN !



- Follow the growth of your animals to ensure the profitability.
- Optimize your production cost by regularly monitoring weights of your animals.
- Weigh your animal with a consistent and accurate equipment to avoid negative prices, and grow your profits !
- **If you have special request on particular dimensions or high capacity scales, we can achieve it ! Do not hesitate to contact us.**

Improve your herd performances !



MECHANICAL WEIGHING FRAME PM 40



Dimensions
length 220 cm or 250 cm
width 94 cm
height 25 cm

Gross weight: 230 kg

locking lever releasing knives for travel 1 2 double beam indicator with stainless steel rulers

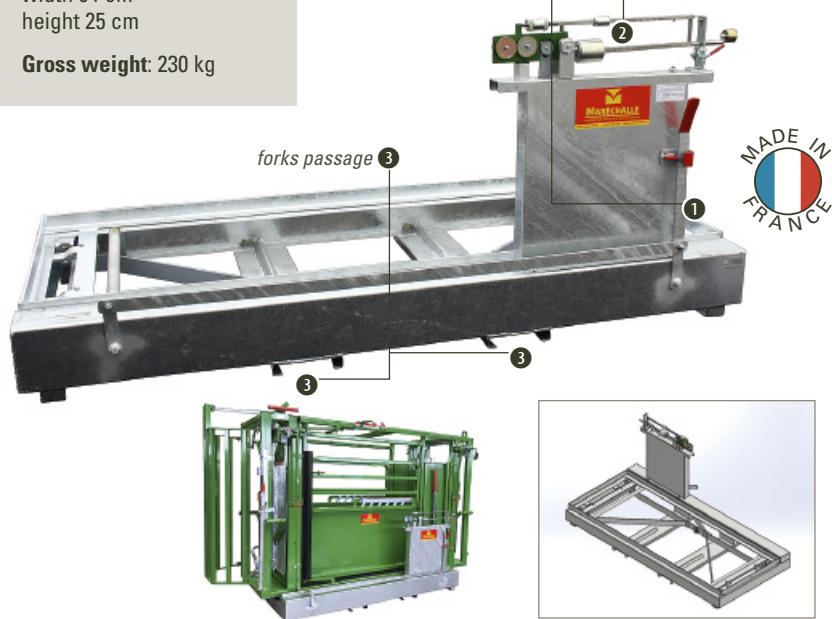

TECHNICAL FEATURES

- Angle frame adaptable to all of our cattle crushes.
- Double beam indicator with stainless steel rulers mounted on a removable case.
- Weighing capacity: 1 500 kg / 1 kg.
- Resistance to violent movements of animals.
- Longevity of the weighing system.
- Easy to move through the passage of forks.

OPTIONS

- Extra charge for weighing capacity of 2,000 kg / 1 kg
- Legal metrology
- Three-point forks PM 30
- Verification report, without legal metrology

SUSPENDED ELECTRONIC WEIGHING FRAME PM 45

Dimensions
length 230 cm
width 130 cm
height 235 cm

Gross weight: 180 kg



TECHNICAL FEATURES

- Reinforced external frame.
- Structure with 4 overhead sensors in nickel-plated steel.
- Weigh indicator of your choice.
- For handling crushes PM 2400 and PM 2800.

PRODUCT BENEFITS

- Resistance to violent movements of animals.
- Longevity of the weighing system.
- Weighing on any type of ground.
- For an intensive use.
- Quickly stabilizes even with very lively animals.
- Lasting investment.

OPTIONS

- Legal metrology (only for indicators I 30, I 40 and I 45)
- Printer for indicators of series 3000 and 5000

WEIGHING CAPACITY

- 2000 kg / 1 kg

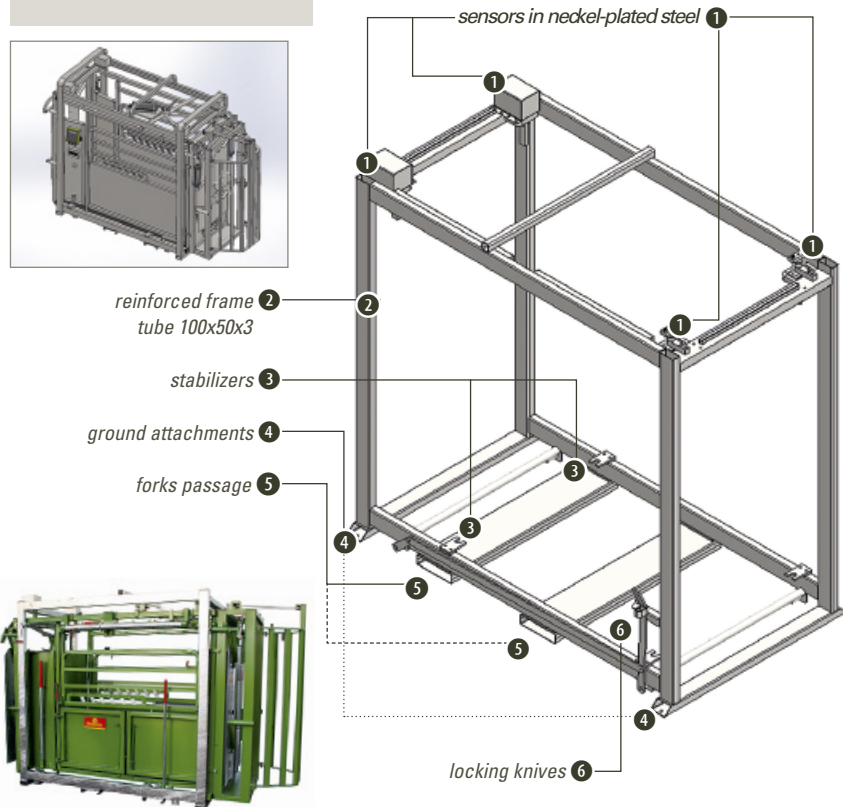

LOAD BARS



4 RÉFÉRENCES

- HD5T, 1115 mm - Weight: 37 kg
- BC120, 1200 mm - Weight: 46kg
- BC100, 1010 mm - Weight: 43 kg
- BC80, 800 mm - Weight: 40 kg
- BC60, 600 mm - Weight: 37 kg

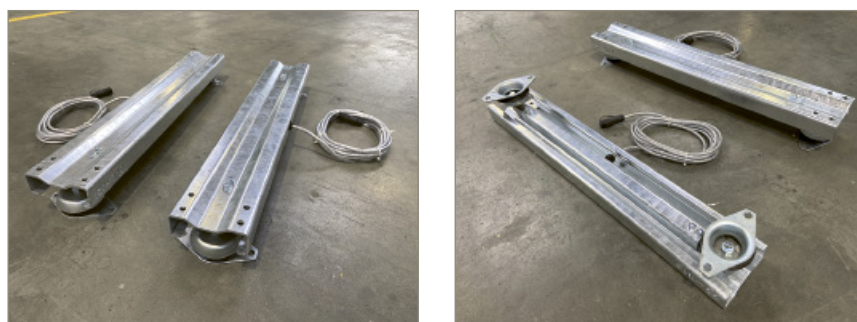
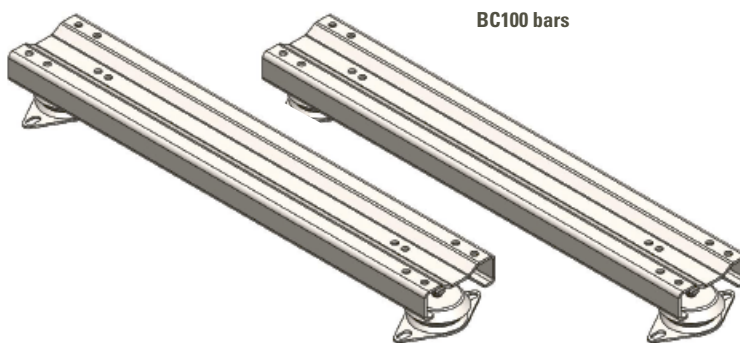
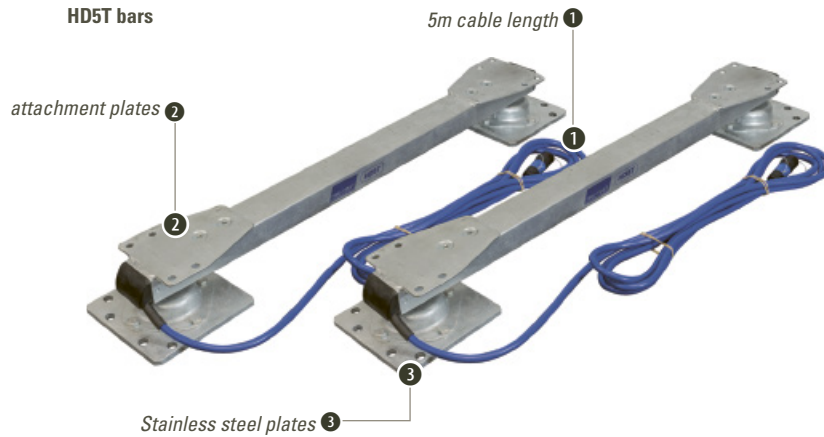

Stainless steel bars

TECHNICAL FEATURES

- Made for a permanent as well as temporary use.
- Compatible TruTest / Datamars indicators S3, EW7, ID5000 and XR5000.
- Robust and durable over time.
- Resistant to violent animal movements, as they have been specially developed for weighing live animals.
- Water, dust and bad weather resistant.
- Steel fixing plates.
- Each bar is equipped with 2 sensors.
- To be installed on a stable and horizontal surface.
- Weighing capacity: 5000kg / 1 kg.

OPTIONS

Verification statement BC

Fixing brackets and crutches

Legal Metrology (only for BC100, BC80, BC60)

WEIGHING CAPACITY

- BC bars: 2000 kg / 1 kg
- HD5T bars: 5000 kg / 1 kg

STAINLESS STEEL LOAD BARS



5 RÉFÉRENCES

- BCI 600: 600 mm
- BCI 800: 800 mm
- BCI 1000: 1010 mm
- BCI 1200: 1200 mm
- BCI 1500: 1500 mm

BCI 1200



BCI 1000



TECHNICAL FEATURES

- Very robust with 4 stainless steel sensors IP67 protection.
- IP67 waterproof connector.
- 5 m braided shielded cables and anti rodents.
- Stainless steel swivel feet.
- Very robust and durable over time.
- Available in length 600, 800, 1000, 1200, or 1500 mm.
- Compatible with all our electronic indicators.
- Weighing capacity: 2,000 kg, multi-step graduation.
- Total resistance: 3,000 kg (1,000 kg tare).

OPTIONS

Verification report, without legal metrology

Legal metrology associated with a load receptor (platform or crush)

WEIGHING CAPACITY

- Up to 2,000 kg / 1 kg



Stainless steel load bars



S3 INDICATOR



TECHNICAL FEATURES



- Simple indicator with internal rechargeable battery.
- IP67 protection, 100% water and dust proof.
- Highly visible bright backlight display.
- Bluetooth® connectivity allows you to record animal weights and configure settings using the Data Link app.
- Record weights using the Data Link mobile app. The S3 weigh scale indicator connects to Data Link to easily record weights and visual ID numbers. These are automatically available in Datamars Livestock, or can be emailed or shared via other apps.
- Up to 15 hours of run time and only 6 hours to recharge.
- Superdamp TM III technology: seize live weighing quickly than any other indicator on the market.

OPTION

Verification report
Without Legal Metrology

INDICATOR PM 650



TECHNICAL FEATURES



- Bluetooth communication with EID readers up to 100 m away.
- Calculates and displays an animal's daily weight gain since the previous session.
- Easily download recorded information with your PC or smartphone.
- Stores up to 20,000 records in 100 weighing sessions.
- Speeds up weight drafting by displaying direction for up to 3 weight ranges.
- Over 15 hours of run time and only 3 hours to recharge.
- IP67 waterproof case with rubber corner buffers.
- Superdamp TM III technology: seize live weighing quickly than any other indicator on the market.

OPTION

Verification report
Without Legal Metrology



INDICATOR JR 5000



TECHNICAL FEATURES



- Wireless or tethered EID reader connectivity. Choose between wireless Class 1 Bluetooth communication with EID readers up to 100m away, or connect via cable.
- Easily transfer recorded information. No matter where you are you can quickly transfer information using your mobile device (Android* or Apple*), USB memory stick or computer (Microsoft Windows*). You can also seamlessly upload sessions via Wi-Fi direct from the device to Data-mars Livestock.
- Capture traits or treatments. Record notes for each individual animal.
- Storage capacity up to 1 million records for 1 thousand weighing sessions.
- Rugged. The new water, dust and shock proof IP67 case with rubber bumpers is the latest in rugged design based on 30 years of experience designing products for use on farm. We have made the tough even tougher.
- Color display with screen clarity in even the brightest sunlight.
- Water, dust and shock proof IP67 case.

OPTIONS

Verification report, without Legal Metrology

Printer

INDICATOR ID 5000



TECHNICAL FEATURES



- Built-in Bluetooth and wifi.
- Possibility to connect a USB key.
- Connections USB and RS232.
- Bluetooth wireless interface up to 100 m.
- Color display with screen clarity in even the brightest sunlight.
- Adapts to any RFID identification system and communicates live on smartphone and computer.
- Calculates the average daily weight gain.
- Track performance through calculating and visualising an animal's weight gain.
- Pre-loaded common setups or save own favourite setups to easily switch between jobs.
- Quickly transfer information through your mobile device (Android or Apple), USB memory stick or computer (Microsoft Windows).
- Long life 13 hours battery and 7 hours charging time.
- Water, dust and shock proof IP67 case.

OPTIONS

Verification report, without Legal Metrology

Printer

INDICATOR XR 5000



TECHNICAL FEATURES



- Built-in Bluetooth and wifi .
- Bluetooth wireless interface up to 100 m.
- Color display with screen clarity in even the brightest sunlight.
- Adapts to any RFID identification system and communicates live on smartphone and computer.
- Depending on the weight displayed, the indicator calculates and displays the exact amount of medication to be administered.
- Stores up to 1 million records in 1,000 weighing sessions and records up to 100 pieces of information for each animal.
- Calculates the average daily weight gain and carcass weight.
- Sorting function: an arrow announces the direction of the animal according to its weight category and several other criteria.
- Long life 13 hours battery and 5 hours charging time.
- Water, dust and shock proof IP67 case.

OPTIONS

- Verification report, without legal metrology
- Printer

INDICATOR I 30



TECHNICAL FEATURES



- 5-key functional waterproof keypad.
- Backlit 25 mm LCD display with 6 high contrast digits with icons for showing the active functions.
- Easy to clean ABS IP54 case, resistant to harsh and corrosive environments.
- Suitable for use on the table, column, or wall.
- Fitted with fixing bracket with adjustable inclination.
- Supplied as standard with 4 AA batteries extractable drawer with 60 hours autonomy, and 12V external power adapter.
- Automatic tare.
- Printing and/or data transmission.

OPTION

- Legal metrology
- RJ11-USB cable
- Bluetooth
- Repetitor



	XR 5000	ID 5000	JR 5000	PM 650	S3	I 30
Color display	✓		✓			
Protection (IP)	IP 67	IP 67	IP 67	IP 67	IP 67	IP 68
Stability indicator light	✓	✓	✓	✓	✓	
Fine resolution mode	✓	✓	✓	✓	✓	
Automatic zero on/off	✓	✓	✓	✓	✓	✓
Battery life	> 10 h	> 10 h	> 10 h	> 15 h	> 20 h	> 60 h
Alphanumeric keyboard	✓	✓	✓	✓		
USB cable connection	✓	✓	✓	✓		option
Bluetooth	✓	✓	✓	✓	✓	option
Compatible with EID devices	✓	✓	✓	✓		
Internal memory	✓	✓	✓	✓		
Number of weighing sessions	1 000	1000	1000	100		
Customizable criteria records	100	3	3	1		
Daily weight gain calculation	✓	✓	✓	✓		
Date and time display	✓	✓	✓	✓		
Basic statistics (average, min, max)	✓	✓	✓	✓		
Maréchal sorting module	✓	✓	✓	✓	✓	✓
Sorting ranges (number of paths)	10	5	5	3		3
Sorting criteria (weight, sex, age, etc.)	multiple	weight + 1 critères	weight	weight		weight
Computer interface software included	✓	✓	✓	✓		
App for Android Smartphone	✓	✓	✓	✓		✓ with Bluetooth
App for Apple Smartphone	✓	✓	✓			
Carcass weight calculation	✓	✓				
History chart of the animal	✓	✓				
Graph of datas on the screen	✓	✓				
Characteristic of medical treatments	✓					
Legal Metrology possible						option

WEIGHING PLATFORM PM 42

**Dimensions**

length 220 cm
width 80 cm

Gross weight: 55 kg

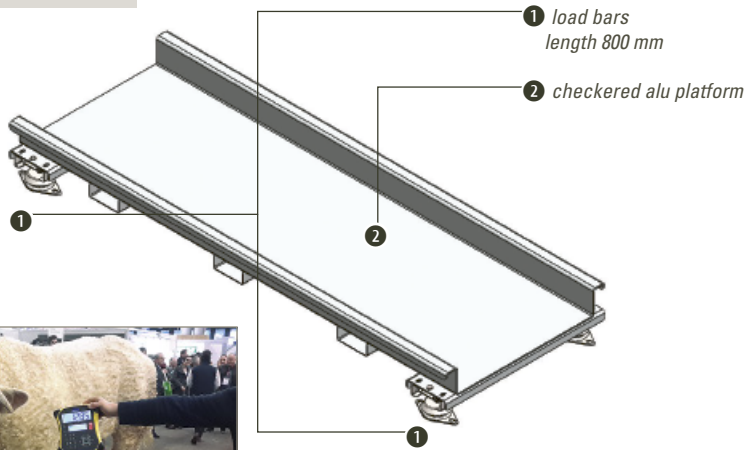
**TECHNICAL FEATURES**

- Compatible with any indicator to choose (not included).
- Aluminium platform with load bars 800 mm.
- Lightweight and easy to move.
- To install on a stable, level surface. Can also be installed in a handling alley.
- Resistance to violent movements of animals.
- Good protection against moisture and dust.

WEIGHING CAPACITY

- 2000 kg / 1 kg

WEIGHING PLATFORM PM 42 FOR HORSES

**Dimensions**

length 200 cm
width 100 cm
height 10 cm

Gross weight: 60 kg

**TECHNICAL FEATURES**

- Compatible with any indicator to choose (not included).
- Lightweight aluminum platform with rubber mat.
- On wheels and with a handle for easy transfer.
- Platform on 4 sensors with swivel feet.
- Height 10 cm well adapted to horses.
- To install on a stable, level surface.

WEIGHING CAPACITY

- 1500 kg / 1 kg



WEIGHING PLATFORM PM 43



Dimensions
length 245 cm
width 80 cm

Gross weight: 140 kg

WATCH

OUR VIDEOS ON



www.marechalle-pesage.com

TECHNICAL FEATURES

- Compatible with any indicator to choose (not included).
- Multifunction electronic weighing platform.
- For various types of weighing: cattle, big bags, pallets etc.
- Galvanized weighing platform with 4 sensors with swivel feet.
- Non-slip and sound absorbing rubber mat.
- Can be installed in a handling alley.

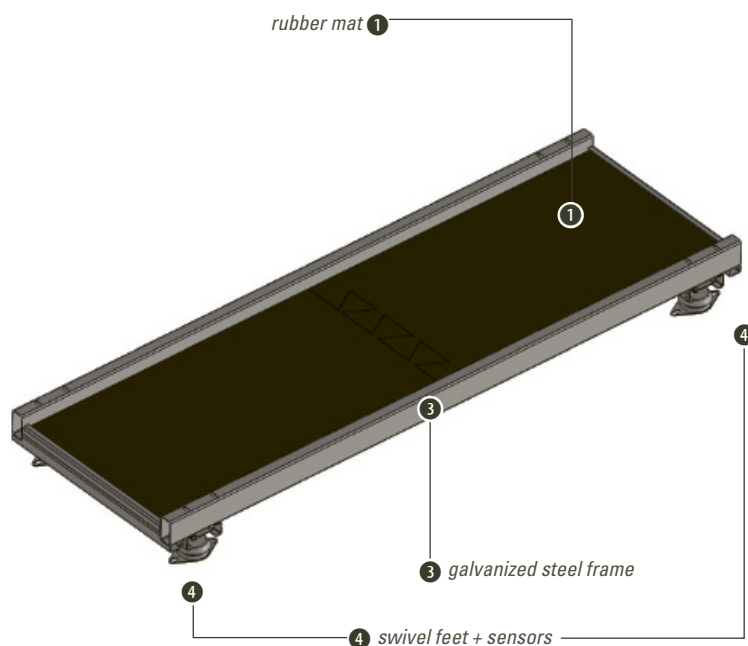

OPTION

Legal metrology (only for the indicators I 30, I 40 and I 45)

WEIGHING CAPACITY

- 2000 kg / 1 kg

WEIGHING PLATFORM PM 41

**Tray dimensions**

100 cm x 100 cm
150 cm x 150 cm
220 cm x 100 cm
220 cm x 120 cm
250 cm x 100 cm
250 cm x 150 cm

Deck height from the ground: 25 cm
Total height: 110 cm

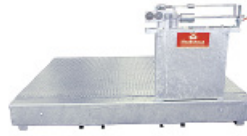

1 double beam with stainless steel rulers

2 treadplate steel platform,

TECHNICAL FEATURES

- Extra-reinforced construction.
- Double beam indicator with stainless steel rulers mounted on a removable case.
- Steel platform fixed on metal framework avoiding any risk of distortion.
- Body surmounted by a sheet metal deck fixed on the frame.
- Weighing mechanism suspended by flanges neutralizing the effect of shocks.
- Setting the tare by threaded wheel.
- Knives and pads in special steel, cadmium plated, 4 bits.
- To install on a horizontal stable surface.

OPTIONS

Extra charge for weighing capacity of 2,000 kg / 1 kg

Legal metrology

Locking knives

WEIGHING CAPACITIES

- 300 kg / 200 g
- 500 kg / 500 g
- 1 500 kg / 1 kg

WEIGHING PLATFORM PM 44

**Possible dimensions**

100 x 100 cm 250 x 100 cm
150 x 150 cm 250 x 150 cm
220 x 100 cm 300 x 200 cm
220 x 120 cm 400 x 200 cm

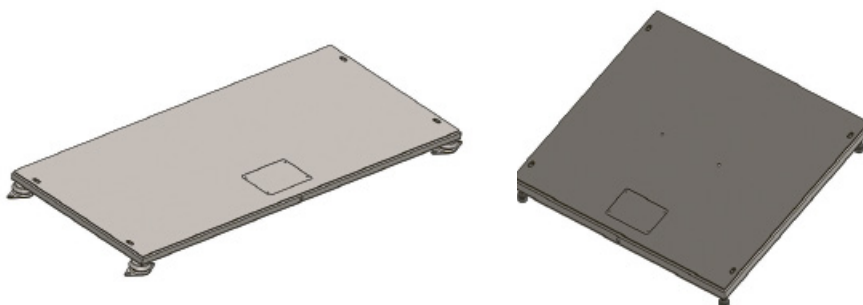
**TECHNICAL FEATURES**

- Weigh indicator of your choice (non included).
- Galvanized steel platform.
- Mounted on pivoting feet with a sensor at each corner.
- To install on a stable, level surface.
- Good protection against moisture and dust.

OPTION

Legal metrology

WEIGHING CAPACITY

- 2000 kg / 1 kg

WEIGHING CRUSH PM110



Internal dimensions

length 150 cm
width at the bottom 25,2 cm
width at the top 40 cm
height 75,5 cm

Gross weight: 70 kg



NEW

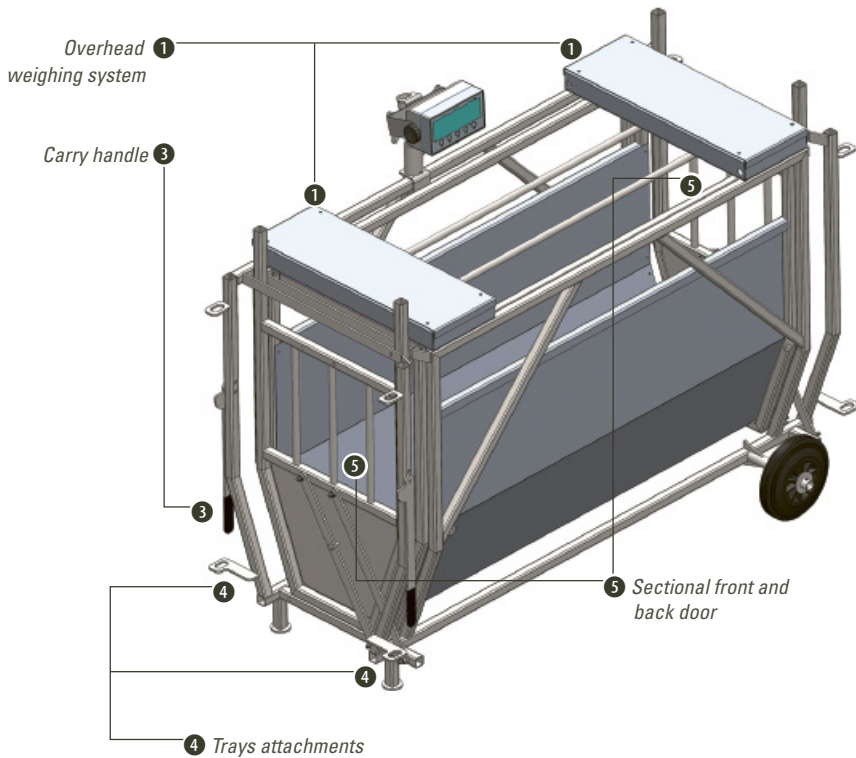

TECHNICAL FEATURES

- Galvanized steel structure and aluminium inner crate.
- Suspended weighing with 2 sensors.
- Indicator of your choice I 30 or PM 650.
- Specially designed for lambs.
- Easily movable with the wheels and retractable transport handles.
- Access to the top of the animal.
- Front and rear sectional doors.
- Anti-slip aluminium crosspieces in the bottom of the crate.
- Ideally combined with the PM 91 sheep sorting gate.
- Compatible with electronic identification.

WEIGHING CAPACITY

- 150 kg / 100g



WEIGHING

OPTIONS

PM 91 sheep sorting gate

Small EID Panel Reader

EID Stick Reader

WEIGHING CRATE PM 120



Internal dimensions

length 110 cm
width 40 cm
height 80 cm

Gross weight: 110 kg



1 electronic indicator of your choice



2 folding doors

3 retractable axle with rubber wheels ø 300

4 load bars 600 mm

5 rubber mat

TECHNICAL FEATURES

- Compatible with any indicator to choose (not included).
- Weighing crate especially designed for small animals.
- Easily movable in the farm through the axle.
- Access on the top of the animal.
- Folding front and rear doors. Fast and easy opening and closing.
- Product available in paint or galvanized.

ANIMAL COMFORT

- Without noise and with opaque sides, you keep your animals more serene.
- No risk of slipping thanks to the rubber mat.

WEIGHING CAPACITY

- 300 kg / 100 g

WEIGHING CRATE PM 200



Internal dimensions

length 150 cm
width 50 cm
height 110 cm

Gross weight: 230 kg



1 overhead mechanical weighing system with double beam



2 overhead hybrid weighing system with electronic indicator of your choice (not included)(non inclus)



3 revolving doors

4 retractable carry handles



5 rubber mat

6 rubber wheels ø 400

TECHNICAL FEATURES

- Compatible with any indicator to choose (not included).
- Mechanical weighing crate with double beam and suspended weighing mechanism.
- or hybrid weighing crate with mechanical overhead system and electronic indicator of your choice (not included).
- Longevity of the weighing system.
- Access to the top of the animal for cares or ultrasounds.
- Access to the animal's teats on the side.
- Easy to move in the farm with retractable carry handles.
- Fast and easy doors' opening and closing.
- Front and back revolving doors, with interchangeable direction.
- Product galvanized only.

ANIMAL COMFORT

- Without noise and with opaque sides, you keep your animals more serene.
- No risk of slipping thanks to the rubber mat.

WEIGHING CAPACITY

- Mechanical crate: 300 kg / 200 g
- Electronic crate: 300 kg / 100 g

WEIGHING CRATE PM 300



Internal dimensions

length 150 cm
width 50 cm
height 110 cm

Gross weight: 230 kg



overhead mechanical weighing system with double beam



TECHNICAL FEATURES

- Compatible with any indicator to choose (not included).
- Mechanical weighing crate with double beam and suspended weighing mechanism.
- or electronic weighing crush with load bars 600 mm and indicator of your choice.
- Access to the top of the animal for cares or ultrasounds.
- Access to the animal's teats on the side.
- Easy to move in the farm with retractable axle and wheels.
- Fast and easy doors' opening and closing.
- Front and back revolving doors, with interchangeable direction.
- Product galvanized only.

ANIMAL COMFORT

- Without noise and with opaque sides, you keep your animals more serene.
- No risk of slipping thanks to the rubber mat.

WEIGHING CAPACITY

- Mechanical crate: 300 kg / 200 g
- Electronic crate: 300 kg / 100 g



WEIGHING CRATE PM 51



Possible dimensions (length x width)

220 x 100 cm 300 x 200 cm
 220 x 120 cm *(only for*
 250 x 150 cm *electronic model)*
 300 x 150 cm height: 100 cm

Warning: width of front and rear doors is always 100 cm.



1 electronic indicator
(not include)

2 100 cm high sheet metal sides

3 revolving doors

4 load bars

1 mechanical weighing frame
with double beam

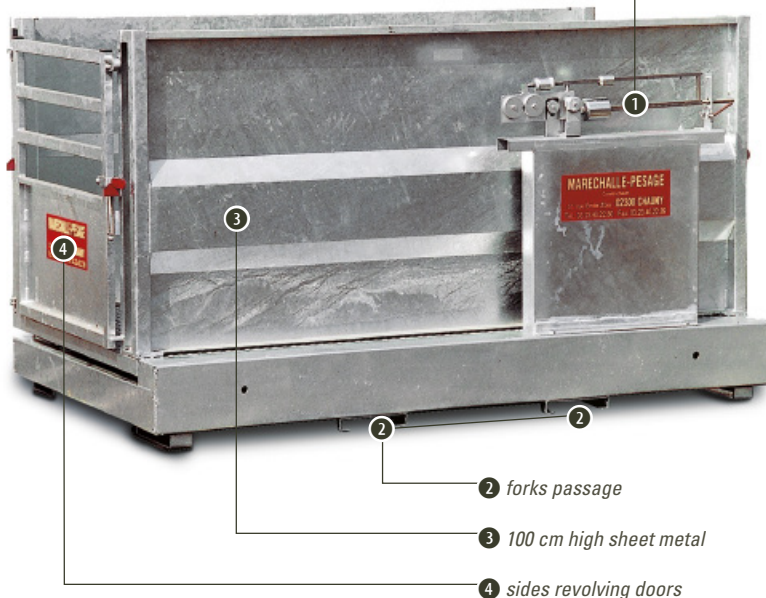

2 forks passage

3 100 cm high sheet metal

4 sides revolving doors

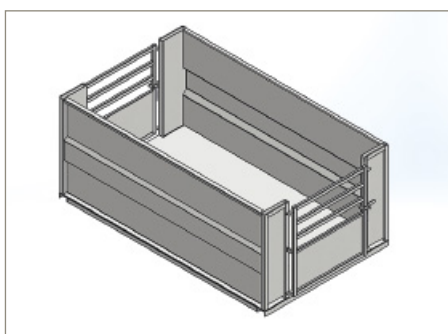

PM 51 en 250 x 150 cm

TECHNICAL FEATURES

- Compatible with any indicator to choose (not included).
- Crate designed to weigh a batch of animals.
- Mechanical weighing with angle frame PM 40.
- or electronic weighing crush with load bars and indicator of your choice
- Fast and easy doors' opening and closing.
- Front and back revolving doors, with interchangeable direction.
- Product galvanized only.

WEIGHING CAPACITY

- Mechanical crate: 1500 kg / 1 kg
- Electronic crate: 2000 kg / 1 kg

OPTIONS FOR MECHANICAL MODEL

Extra charge for weighing capacity of 2,000 kg / 1 kg

Legal metrology

PM 30 three-point forks

Locking knives

Rubber mat

OPTION FOR ELECTRONIC MODEL

Rubber mat (*contact us*)

AUTO-WEIGHING CRUSH PM 6000 LIBERTY



Internal dimensions

length 300 cm
width 82 cm
height 190 cm

Gross weight: 750 kg

WATCH
OUR VIDEOS ON



www.marechalle-pesage.com



TECHNICAL FEATURES

- Weighing crush operating in complete autonomy.
- Weighing without stopping thanks to the indicator WOW XR 3000.
- Weights auto recording with numbers of electronic ear tags.
- RS 232 and USB cables for data transfer to your computer.
- The weighing crush can be used outdoors or in stalls.
- Easy to move with forks passage and with three points linkage.
- Possibility to add a solar panel for extended battery life.

OPERATION

First: Entrance into the crush

The front door is closed, the back door is open. The animal comes in and, by stepping on the pedals of the floor, activates the closure of the back door.

Second: the animal is weighed and identified

Crossing the crush, the animal is identified with the EID panel reader, and at the same time weighed by the indicator WOW XR 3000. This indicator is able to stabilize and record weight without the animal pausing for a time on the scale.

Third: Exit

To exit the crush, the animal pushes on the front flaps' door and therefore activates the opening of the front and back doors. Once the animal is out, the front door closes down. The crush is back in standby position.

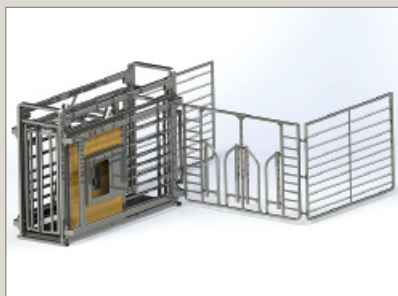

PRODUCT BENEFITS

- The purpose of this weighing crush is to have a very precise control of the weight of your herd.
- No intervention or human presence, so the animal is never stressed.
- Takes away the burden of weighing.

OPTIONS

Solar Panel

Three-parts gate with 1 including 2 backstop doors

Verification report, without legal metrology

WEIGHING CRUSH PM 61



Internal dimensions

length 240 cm
width 82 cm
height 170 cm

Gross weight: 500 kg

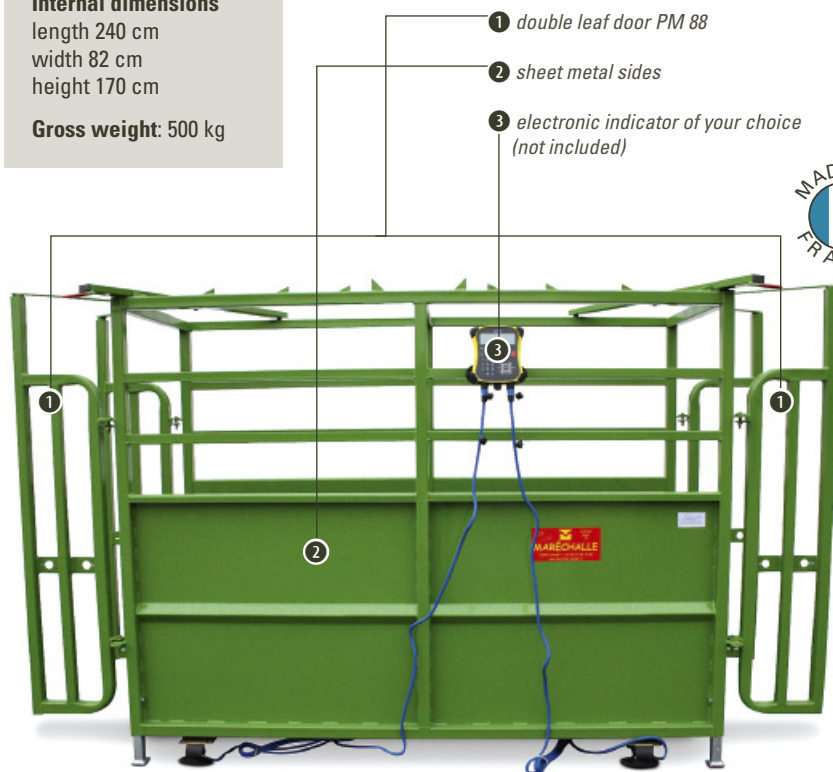

1 double leaf door PM 88

2 sheet metal sides

3 electronic indicator of your choice (not included)

TECHNICAL FEATURES

- Mechanical weighing with angle frame PM 40.
- or electronic weighing crush with load bars and indicator of your choice (not included).
- Double-leaf front and back doors PM 88.
- Easy to move in the farm by three-points linkage.
- Three-points linkage for transfer.
- Checker plate floor.
- Is also suitable for horses with removable raisers.
- Product available in paint or galvanized.

OPTIONS FOR MECHANICAL MODEL

Extra charge for weighing capacity of 2,000 kg / 1 kg

Legal metrology

PM 30 three-points forks

Locking knives

Rubber mat

Verification report, without legal metrology

Width reducer

crush for horses



OPTIONS FOR ELECTRONIC MODEL

Rubber mat

Verification report, without legal metrology

Width reducer

OPTIONS FOR HORSES MODEL

Rubber mat

Removable raisers from 1.70 m to 2.20 m and ordinary doors

WEIGHING



4 double leaf door PM88

5 sheet metal sides

6 locking knives

7 mechanical weighing frame with double beam

8 forks passage

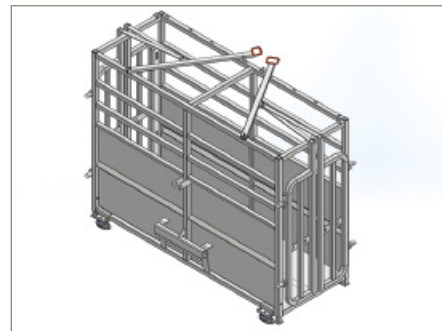

HYBRID WEIGHING CRUSH PM 1600

>>> with possibility of handling



TECHNICAL FEATURES

- Weighing mechanism suspended by flanges neutralizing the effect of shocks.
- Knives and pads in special steel, cadmium plated, 4 bits.
- Electronic indicator of your choice (not included) attached under cover in a box.
- Longevity of the weighing system against shocks and dirt.
- 2 three-point linkages, one reinforced for traveling on the road.
- Locking knives system for transfer.
- Access to the front of the animal for various treatments through the side door.
- Weighing on any type of ground.
- Ideal for an intensive use.
- Product available in paint or galvanized.

WEIGHING CAPACITY

- 2000 kg / 1 kg

OPTIONS

Mechanical weighing system with double beam

Printer (compatible with indicators 3000, 5000 and I30)

Verification report, without legal metrology

Legal metrology (only for indicators I30, I40 and I45)

Reverse model for crush: handles on the left from a front view

SUPER model (hoof trimming equipment)

Manual or pneumatic scoop head up

Medicine box

Rubber mat

Width reducer

Galvanised Muzzle boom lift

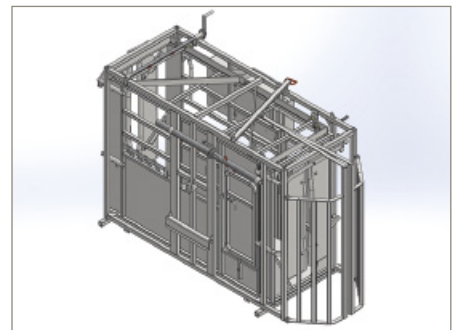

Internal dimensions

length 240 cm

width 82 cm

height 165 cm

Gross weight: 770 kg

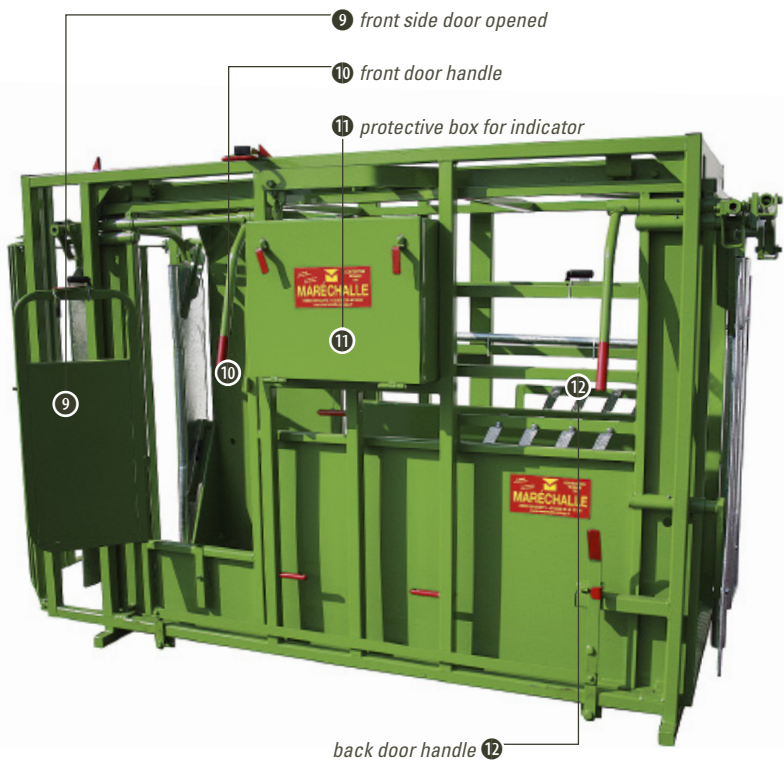
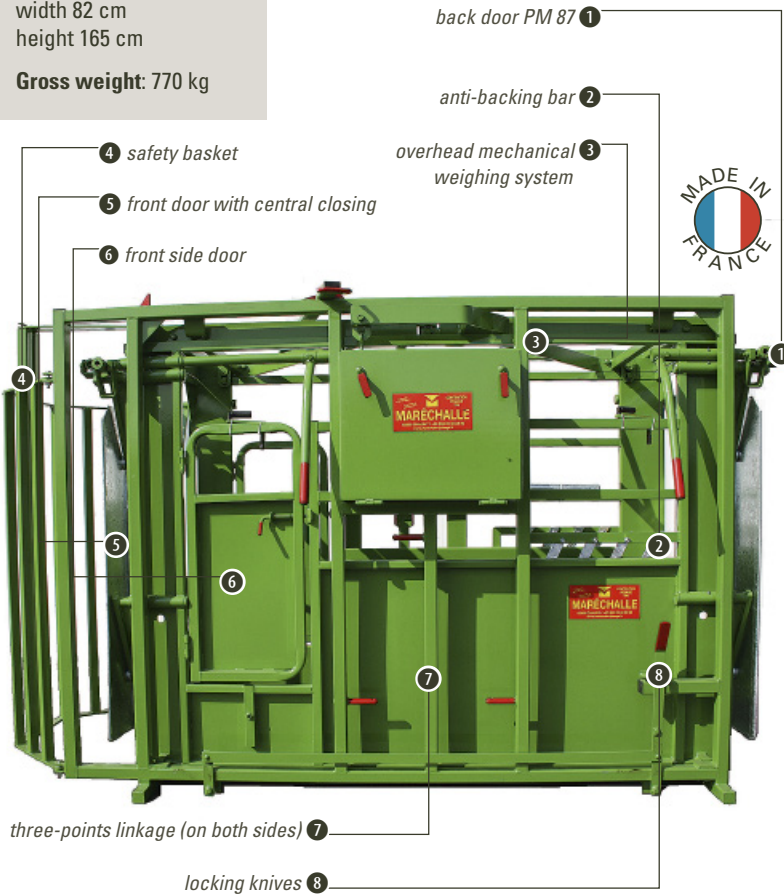

HYBRID WEIGHING CRUSH PM 1200

>>> for intensive traffic



Internal dimensions

classic model

length 240 cm

width 82 cm

height 165 cm

Gross weight: 770 kg

reinforced model

length 270 cm

width 102 cm

height 180 cm

Gross weight: 950 kg



option measurement chain: 1 sensor with 1 indicator (not included)

double beam (option)

back door PM 87 with central closing

TECHNICAL FEATURES

- Weighing mechanism suspended by flanges neutralizing the effect of shocks.
- Knives and pads in special steel, cadmium plated, 4 bits.
- Electronic indicator of your choice (not included) mounted under cover in a box.
- Longevity of the weighing system against shocks and dirt.
- Locking knives system for transfer.
- Weighing on any type of ground.
- Extra-reinforced construction designed for an intensive use.
- Ideal for an intensive use.
- Stationary. Model designed for allotment centers or slaughterhouses.
- Front and back doors PM 87.
- Product galvanized only.

OPTIONS

Mechanical weighing system with double beam

Printer (compatible with indicators 3000, 5000 and I 30)

Verification report, without legal metrology

Legal metrology (only for indicators I 30, I 40 and I 45)

Rubber mat for classic model

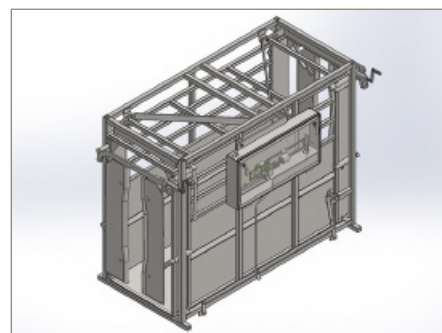

Reinforced PM 1200 used for the official weighing contest at the International Agriculture Show in Paris.

WATCH
OUR VIDEOS ON



www.marechalle-pesage.com

TRACTABLE WEIGHING CRUSH PM 1020 T

>>> with overhead weighing system and adjustable width

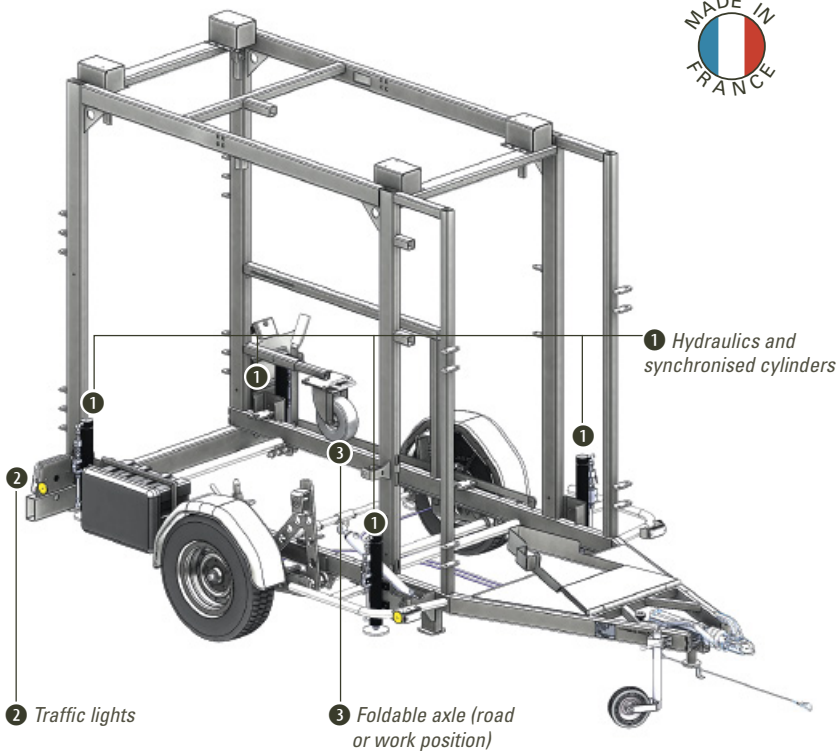

TECHNICAL FEATURES

- Trailer permit required.
- Weighing suspended by 4 ball sensors.
- Electronic indicator of your choice (not included).
- Longevity of the weighing system against shocks and dirt.
- Locking of the weighing system for transport.
- Handling crush adjustable in width.
- Product galvanized only.
- Quick installation and leveling with hydraulic system.
- Trailer approved for registration and road transport only in Europe.
- Approved to travel on public roads up to 140 km/h.
- Handling crush adjustable in width.
- The platform placed completely on the ground prevents too high of a step for the animals to enter the cage.
- The animals can thus enter easily, saving time on interventions such as weighing, care, restraint, etc.

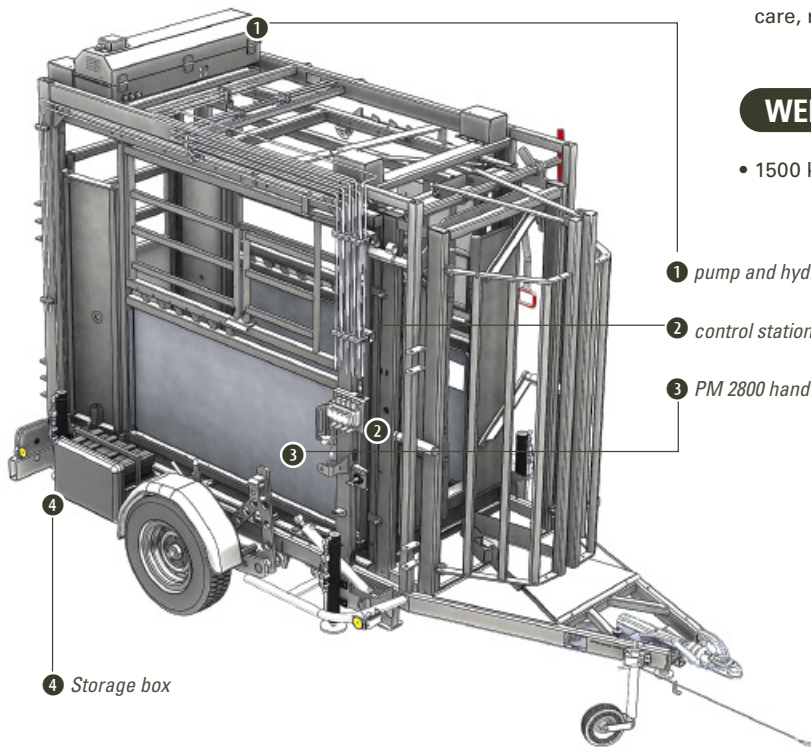

WEIGHING CAPACITY

- 1500 kg / 1 kg

WEIGHING



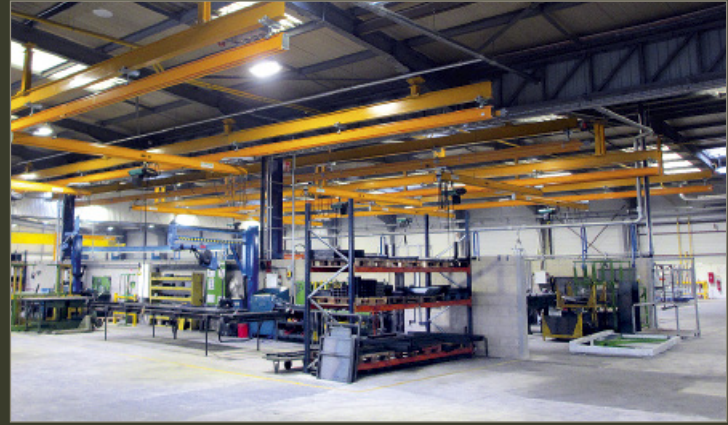

OUR FACTORY

Since June 2015, we have moved to our new factory located in Chauny, Northern France, between Lille and Paris.

Implanted in 18 000 square metres industrial estate, all our products are manufactured in our 6000 square meters factory.

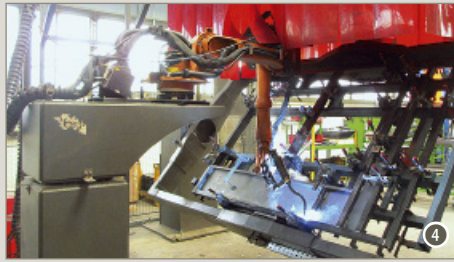
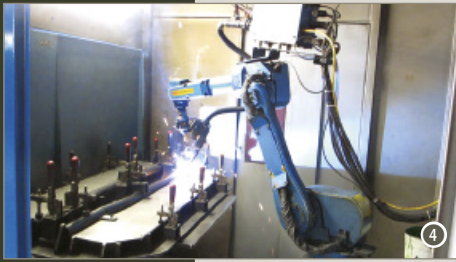

INDUSTRIAL MACHINERY

- ① SHEET STEEL LASER CUTTING
Power: 3 200 Watts
Steel: 20 mm
Stainless steel: 10 mm
Aluminium: 8 mm
- ② STEEL TUBE LASER CUTTING
Power: 2 000 Watts
Steel: 8 mm
Stainless steel: 4 mm
Aluminium: 3 mm
- ③ PRESS BRAKE
Press brake of 3 m length
- ④ 2 WELDING ROBOTS
1 robot 10 axes
1 robot 7 axes
- ⑤ DEGREASING STATION
Zero rejection for the environment
- ⑥ PAINTING BOOTH
Length: 12 m
Width: 4 m
Height: 4 m

INFORMATIONS

TRAIDE SHOWS

Every year, we present and exhibit our products on many agricultural shows. We are always very concerned and interested about receiving your feedbacks regarding our products. As our goal is to improve continuously our brand, we seek to provide a simpler, safer and convenient futur with you.

GUARANTEES

Our products benefits a guarantee of one year starting from the expedition date against any manufacturing or material defects. Our responsibility can only be requested for the substitute of the pieces or parts recognised as faulty or defectives, without any indemnity included. Shipping fees, whatever they may cost, are always the customer's responsibility.

GALVANISING

In order to prevent the corrosion of the steel and zinc that can be deteriorated by a extended contact to manure, we strongly recommend to use the TR0005 bituminuous paint before any use of the product. We also recommend to apply this paint periodically to prevent any deterioration that may occur.

SIGNIFICANT INFORMATIONS

- The transport by road of our products such as weighing crates, handling crushes or handling alleys has to be done accordingly to the regulation and applicable law. MARECHALLE will not be held responsible or incur any liability for any damages whatsoever resulting from a non-compliance with regulations.
- For proper use of the products, it is mandatory to regularly check the tightness of the equipment and to grease the moving parts.
- Despite all the care we put into designing our products with the primary goal of ensuring optimal animal welfare and maximum safety, Maréchalle cannot be held responsible in the event of an accident involving an animal. The daily knowledge and monitoring of animals by the farmer remain the most secure solution to prevent accidents.



JOIN US ON OUR SOCIAL MEDIA PLATFORMS
and follow all our events live !



INDEX

AUTO-LOCKING HEADGATE PM 85 _____	9	MECHANICAL WEIGHING FRAME PM 40 _____	39
AUTOMATIC HEADGATE PM 97 _____	6	MULTIFUNCTION CRUSH ALL IN ONE PM 2400 _____	12
AUTO-WEIGHING CRUSH PM 6000 LIBERTY _____	53	PNEUMATIC AUTOMATION _____	20
BACKSTOP DOOR PM 89 _____	11	PORTABLE HANDLING ALLEY PM 3200 _____	22
BARCODE SCANNER _____	36	REINFORCED HEADGATE PM 94 _____	7
CALVES DEHORNING BOX PM 170 _____	21	REINFORCED HYDRAULIC PM 2855 _____	18
CORNADIS HEADGATE PM 80 _____	10	S3 INDICATOR _____	42
EID PANEL READERS _____	35	SHEEP SORTING GATE PM 91 _____	4
ELECTRIC HOOFTRIMMING CRUSH WITH 1 MOTOR PM 4450 _____	28	SHEEP SORTING GATE PM 92 _____	4
ELECTRIC HOOFTRIMMING CRUSH WITH 1 MOTOR PM4400 _____	27	SLIDE-OVERTREATMENT CRUSH PM 4200 _____	25
ELECTRIC HOOFTRIMMING CRUSH WITH 6 MOTORS PM 4600 _____	29	SLIDING DOOR PM 81 _____	11
ELECTRONIC EARTAGS _____	33	SORTING GATE PM 90 FOR BOVINE _____	3
ERGONOMIC SQUEEZE CATTLE CHUTE PM 2900 _____	15	SQUEEZE CATTLE CHUTE PM 2805 _____	13
GATE PM 87 _____	10	SQUEEZE CATTLE CHUTE PM 2810 _____	14
HANDLING ALLEY _____	5	STAINLESS STEEL LOAD BARS _____	41
HANDLING OPTIONS _____	16	STICKS READERS XRS2 _____	34
HYBRID WEIGHING CRUSH PM 1200 _____	56	SUSPENDED ELECTRONIC WEIGHING FRAME PM 45 _____	39
HYBRID WEIGHING CRUSH PM 1600 _____	55	TRACTABLE WEIGHING CRUSH PM 1020T _____	57
HYDRAULIC HOOFTRIMMING CRUSH PM4700 _____	30	TRAILER TRAY PM 1030T _____	23
HYDRAULIC PM 2900 _____	19	TREATMENT BOX FOR HORSES PM 2007 _____	31
INDICATOR I 30 _____	44	UNIVERSAL HEADGATE PM 93 _____	8
INDICATOR ID 5000 _____	43	WEIGHING CRATE PM 120 _____	50
INDICATOR JR 5000 _____	43	WEIGHING CRATE PM 200 _____	50
INDICATOR PM 650 _____	42	WEIGHING CRATE PM 300 _____	51
INDICATOR XR 5000 _____	44	WEIGHING CRATE PM 51 _____	52
INDICATORS SUMMARY TABLE _____	45	WEIGHING CRUSH PM 61 _____	54
LOAD BARS _____	40	WEIGHING CRUSH PM110 _____	49
MANUAL HOOFTRIMMING CRUSH PM 4300 _____	26	WEIGHING PLATFORM PM 41 _____	48
MARÉCHALLE SOFTWARE _____	37	WEIGHING PLATFORM PM 42 _____	46
		WEIGHING PLATFORM PM 42 FOR HORSES _____	46
		WEIGHING PLATFORM PM 43 _____	47
		WEIGHING PLATFORM PM 44 _____	48



MARECHALLE

CONTENTION ■ PESAGE ■ IDENTIFICATION

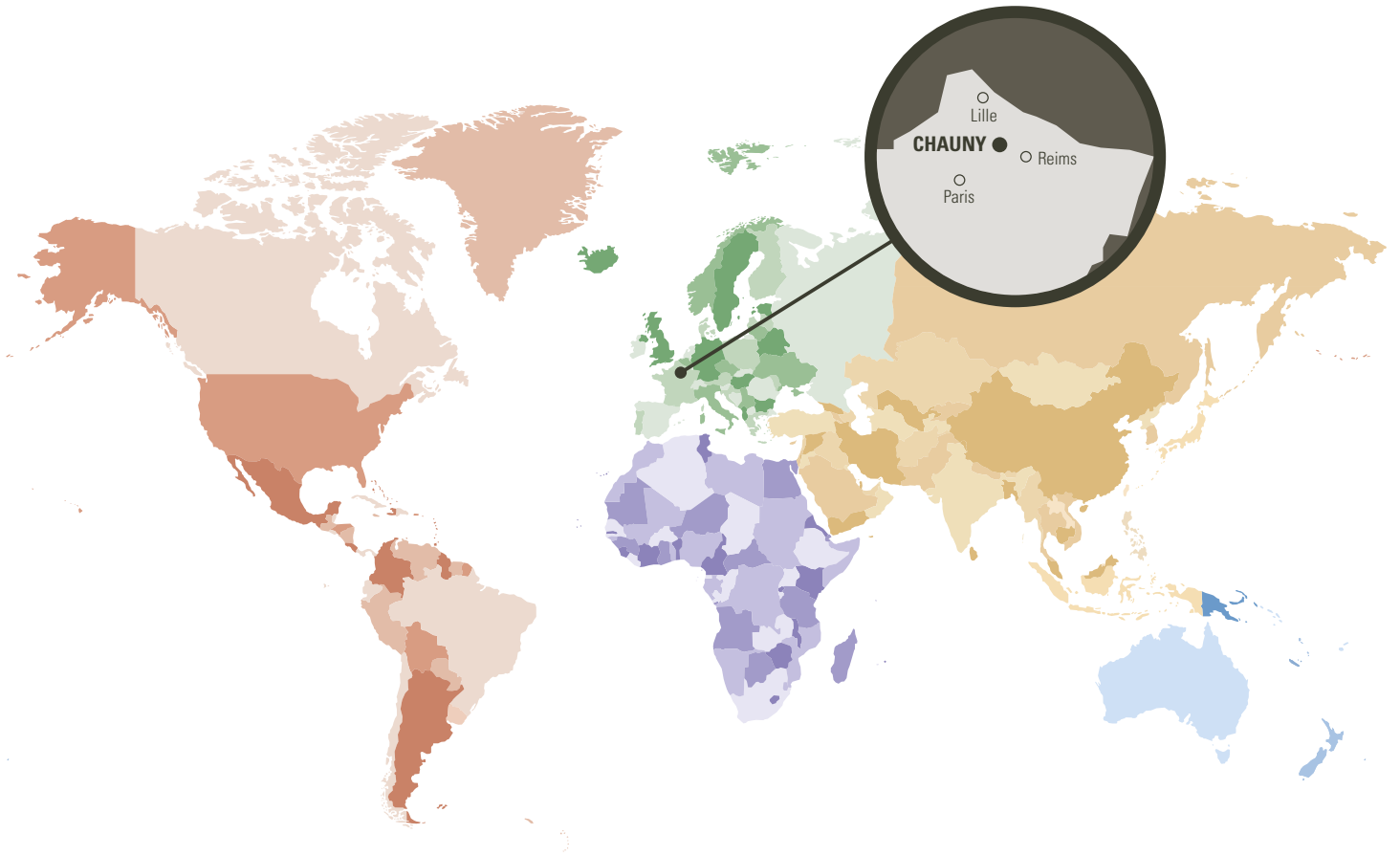

130 C Avenue Jean Jaurès - BP 70019
F-02300 Chauny - FRANCE
Tél. +33 (0)3 23 40 22 80
contact@marechalle-pesage.fr

Reseller:



www.marechalle-pesage.com